

F I A T I D E A





The innovating Windows Mobile™-based Telematic Solution for the car

CONTENTS

OVERVIEW	3	Audio	17
The hands-free kit.....	3	Blue&Me™ function menu	18
Message reader	5	HANDS-FREE KIT FUNCTIONS.....	19
Media player	6	Making a phone call	19
Road safety	7	Incoming calls	23
		Managing phone calls	23
DISPLAY AND BUTTONS ON THE STEERING WHEEL.....	8	Conference call function	24
		MESSAGE READER FUNCTIONS.....	25
HANDS-FREE KIT QUICK REFERENCE GUIDE.....	10	How to read the last SMS text received.....	25
Prepare your mobile phone phonebook	10	Inbox	26
Try out the voice commands	11	Managing messages.....	26
Pair your mobile phone	11	Deleting all messages.....	27
Make a phone call	12	Signal types.....	27
		MEDIA PLAYER FUNCTIONS	28
MESSAGE READER QUICK REFERENCE GUIDE	13	How to connect the USB device to Blue&Me™	28
		How to manage the media library	29
MEDIA PLAYER QUICK REFERENCE GUIDE	13	- Selection by folder	29
		- Selection by artist	30
HOW TO USE Blue&Me™	14	- Selection by genre	30
Steering wheel controls	14	- Selection by album	31
Voice commands	14	- Selection by playlist	31
Display	17		

Playing audio tracks	32	Blue&Me™ SUPPORTED MOBILE PHONES	44
- Shuffle playback of the whole media library	32	Mobile phones with Bluetooth® wireless technology	44
- Now playing (track data)	32	- “Pull” phones (phonebook automatically downloaded)	44
- Audio play	32	- “Push” phones (phonebook not automatically downloaded)	44
- Pause	32	- Mobile phones with message reader	44
- Play	32	Supported USB memory devices	45
- Stop	33	- Management of audio files from iPod devices	45
- Next track	33	- USB memory devices	45
- Previous track	33	- Supported digital audio files	46
- Changing audio source	33	- Supported playlist formats	47
Practical hints for using the media player	34	VOICE COMMANDS (KEYWORDS) - SUMMARY	48
- Scrolling	34	Always available voice commands	48
- Organizing media files	34	Hands-free phone kit voice commands	49
- Building the media library on Blue&Me™	34	Message reader voice commands (keywords)	51
- Building playlists for Blue&Me™	34	Media player voice commands	52
SETTINGS FUNCTIONS	35	Settings function voice commands	55
Pairing a mobile phone	35	TROUBLESHOOTING	56
Managing user data	38	Hands-free kit	56
Media player settings	41	- General - display screen	56
- Autoplay	41	Message reader	64
- Shuffle	41	Media player	66
- Loop	42	iPod	70
Advanced options	42	PERSONAL DATA PROTECTION	72
- Accessing the device ID	42	SYSTEM SOFTWARE USE NOTICE	73
- Changing the GPRS code	43		
Exit the settings menu	43		

Hands-free kit with Bluetooth® wireless technology, message reader and media player

OVERVIEW

Windows Mobile™-based Fiat **Blue&Me™** is a personal telematic system enabling to use communication and entertainment applications expressly designed for use in the car.

The **Blue&Me™** system installed on your car is equipped with hands-free kit, message reader and media player, and it is pre-set for future installation of additional services.

Note

Not all mobiles support the voice reading of SMS or the automatic transfer of the directory through **Bluetooth®**. For further information, surf the web site www.fiat.com to find out the list of compatible mobiles.

The **Blue&Me™** system, fully integral with voice commands, buttons on the steering wheel and multifunction display messages, gives you the possibility of interacting with your **Bluetooth®** wireless technology mobile phone (even if you keep it in your pocket or bag) without having to take your eyes off the road or removing your hands from the steering wheel. To use voice commands you are not required to train the voice recognition system to recognize your voice. This implies that the system is nearly equally performing with different persons, i.e.: the voice recognition system is of the “speaker independent” type.

With this system you can also play your favourite music stored on USB device and select tracks and playback modes with both voice commands or buttons on the steering wheel.

THE HANDS-FREE KIT

The basic characteristic of this hands-free kit is voice recognition with **Bluetooth®** wireless technology. With this system you can make and receive calls safely and securely using either voice commands or buttons on the steering wheel under whatever driving condition without having to take your eyes off the road or removing your hands from the steering wheel, as required by current law regulations.

Bluetooth® wireless technology enables wireless connection between your mobile phone and the hands-free kit installed on your car.

To use the hands-free kit, you need a **Bluetooth**[®] wireless technology enabled mobile phone. This hands-free kit gives you the possibility of interacting vocally with your mobile phone while driving, even if your mobile device does not feature this capability. You can also interact with your mobile phone manually and visually using the steering wheel controls and the instrument panel multifunction display.

For further details on the mobile phones supported by **Blue&Me**[™], refer to section **Blue&Me**[™] SUPPORTED MOBILE PHONES.

To get started with **Blue&Me**[™] hands-free kit with voice recognition, you have to simply pair your **Bluetooth**[®] wireless technology enabled mobile phone with the system.

Pairing is an operation that has to be made only once.

Note

During the mobile phone pairing procedure, **Blue&Me**[™] attempts to detect a phone equipped with **Bluetooth**[®] wireless technology within range and then establishes the connection using a Personal Identification Number (PIN).

Once your phone is paired, you have the option to transfer your mobile phone contacts to the hands-free kit, to make a phone call either by using the contacts list or directly pronouncing the phone number, to answer a call and also to answer another incoming phone call.

To interact with **Blue&Me**[™] you can use either buttons on the steering wheel and voice commands. With voice recognition, you can perform system function by speaking voice commands, also identified as “keywords”. When the system recognizes a keyword, it will respond with the appropriate action. Voice recognition is an easy and convenient way to use **Blue&Me**[™].

All the system functions are available within the **Blue&Me**[™] Main Menu. When the car is not moving, you can surf through the menu using either buttons on the steering wheel and voice commands. When you are travelling, you can interact with **Blue&Me**[™] using buttons on the steering wheel or voice commands relevant only to phone functions (**LAST CALLS** and **PHONEBOOK**) and media player. To activate settings when travelling you can only use voice commands.

The hands-free kit enables the following operations:

- ❑ **Contact calling by voice** - you can call a contact in your mobile phone phonebook using your voice. You can also call a contact in your phonebook by scanning through the entries on the multi-function display.

(To use this option you have to transfer your mobile phone contacts to the hands-free kit phonebook).

- ❑ **Digit-dialling by voice** - you can dial a phone number by speaking the digits to be dialled.
- ❑ **To call the SMS text sender** - call directly the last SMS text sender or the sender of a message received and stored yet in the **Blue&Me™** inbox.
- ❑ **To answer a call** - you can answer an incoming call by pressing the key  on the steering wheel.

- ❑ **Conference Call** - you can call another contact while you are engaged in a phone conversation (with **Bluetooth®** phones supporting this option)

- ❑ **Call waiting** - while engaged in a phone conversation, you can receive notification of another incoming phone call, answer the other incoming phone call, and switch between two ongoing phone conversations. (Call waiting is only supported by a subset of compatible mobile phones).

After you place your mobile phone in the car environment and create a pairing relationship with **Blue&Me™**, you can make phone calls by speaking keywords or pressing buttons on the steering wheel. When using the hands-free phone, the audio output of a phone conversation is heard through your car sound speakers.

MESSAGE READER (with compatible mobile phones only)

The **Blue&Me™** message reader enables automatic reading, through the car sound system, of the SMS texts you receive on your **Bluetooth®** wireless technology mobile phone. The message reader will also interpret any abbreviation and emoticon contained in the SMS text.

Message reader functions are managed by the control buttons on the steering wheel or by the **Blue&Me™** voice commands.

The **Blue&Me™** message reader enables the following operations:

- ❑ To display on the instrument panel multifunction display a visual notification signal indicating that you have received a new SMS text on your **Bluetooth®** wireless technology mobile phone, with sender's number/name; **Blue&Me™** will also propose you to read the message received
- ❑ To manage the list of SMS texts received on your **Blue&Me™** paired mobile phone

- To read again the messages received and stored
- To call the SMS text sender using the buttons on the steering wheel or voice commands
- To delete individual messages or the entire inbox using the buttons on the steering wheel or voice commands.

The **Blue&Me™** system can also recognize and read abbreviations, if any (e.g. “ILUVU” will be read like “I love you”) and interpret the most usual emoticons (e.g. :-)) will be read like “Smile”), adopted nowadays to write SMS texts.

MEDIA PLAYER

With the **Blue&Me™** media player you can play, via the car sound system, the digital audio files stored on a USB device by simply connecting it to the USB port located in the car.

In this way, while you are driving you can play your favourite personal music collections.

- iPod** player - see dedicated paragraph.

The media player enables the following operations:

- Digital audio playback** - you can play all your digital audio files (.mp3, .wma, .wav, .aac) or play a customized playlist (.m3u or .wpl format).
- Audio file selection by category** - you can play all audio files of a certain category, e.g.: album, artist or genre.
- Playback options** - while playing tracks you can select the following options: *Play, Stop, Next track, Previous track, Shuffle* and *Loop track*.

Note

The media player does not support audio files compressed with other formats and DRM (Digital Right Management) protected audio files. Non-supported audio files that may be present on the USB device will be ignored.

To use the media player, you have to simply connect (directly or by an extension lead) your USB device to the car USB port. Turning the ignition key to **MAR**, **Blue&Me™** will start building your media library. At the end of this operation you can surf the whole library and scroll its categories as required using the buttons on the steering wheel or voice commands. **Blue&Me™** will then play your selection via the car sound system.



WARNING

Operating certain parts of this system while driving can distract your attention away from the road, and possibly cause an accident or other serious consequences; for this reason certain functions shall only be used when driving conditions are secure and, if required, only when the car is stopped.



WARNING

Read and Follow Instructions: before using your system, read and follow all instructions and safety information provided in this end user manual (“User’s Guide”). Not following precautions found in this User’s Guide can lead to an accident or other serious consequences.

Keep User’s Guide in the car: when kept in the car, the User’s Guide will be a ready reference for you and other users unfamiliar with the system. Please make certain that before using the system for the first time, all persons have access to the User’s Guide and read its instructions and safety information carefully.

WARNING: Operating certain parts of this system while driving can distract your attention away from the road, and possibly cause an accident or other serious consequences. Do not change system settings or enter data non-verbally (using your hands) while driving. Stop the car in a safe and legal manner before attempting these operations. This is important since while setting up or changing some functions you might be required to distract your attention away from the road and remove your hands from the wheel.

GENERAL OPERATION

Voice Command Control: functions within the system may be accomplished using only voice commands. Using voice commands while driving allows you to operate the system without removing your hands from the wheel.

Prolonged Views of Screen: do not access any function requiring a prolonged view of the screen while you are driving. Pull over in a safe and legal manner before attempting to access a function of the system requiring prolonged attention. Even occasional short scans to the screen may be hazardous if your attention has been diverted away from your driving task at a critical time.

Volume Setting: do not raise the volume excessively. Keep the volume at a level where you can still hear outside traffic and emergency signals while driving. Driving while unable to hear these sounds could cause an accident.

Use of Speech Recognition Functions: speech recognition software is inherently a statistical process which is subject to errors. It is your responsibility to monitor any speech recognition functions included in the system and address any errors.

Distraction Hazard: any features may require manual (non-verbal) setup. Attempting to perform such set-up or insert data while driving can seriously distract your attention and could cause an accident or other serious consequences. Stop the vehicle in a safe and legal manner before attempting these operations.

DISPLAY AND BUTTONS ON THE STEERING WHEEL

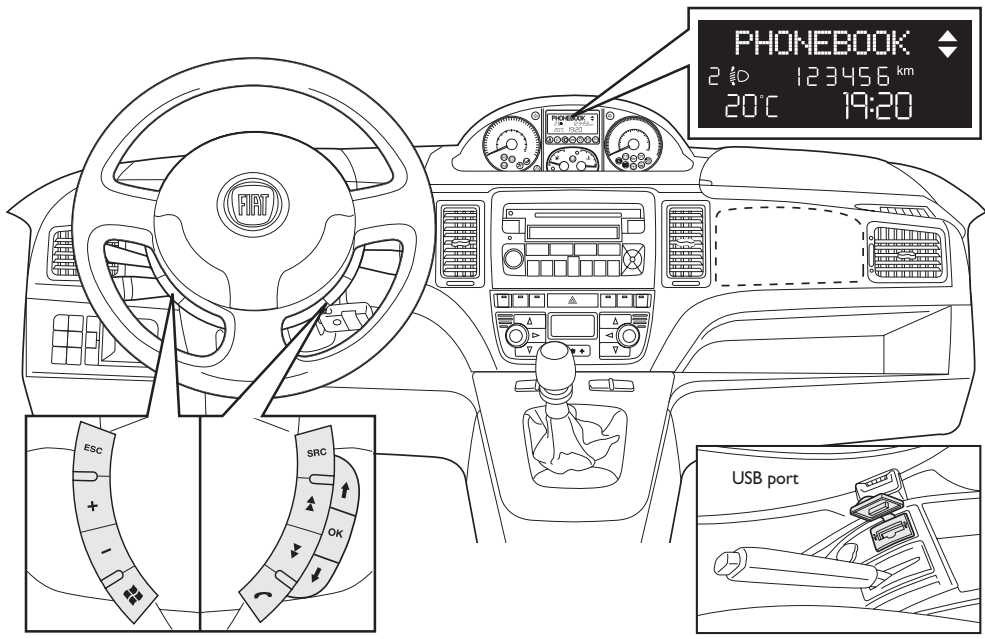







fig. 1

Button	Short press function (less than 1 second)	Long press function (more than 1 second)
	<ul style="list-style-type: none"> – Launch Blue&Me™ Main Menu – Confirm selected menu option – Accept an incoming phone call – Switch between two ongoing phone conversations (call waiting) – Select displayed SMS message 	<ul style="list-style-type: none"> – Reject an incoming phone call – End a phone call (hang up)
ESC	<ul style="list-style-type: none"> – Cancel voice recognition – Cancel a voice announcement – Interrupt message reading – Exit Blue&Me™ Main Menu – Exit the sub-menu and return to the previous menu option – Exit current menu option without storing settings – Turn the microphone on/off during a phone conversation – Mute the ring tone of an incoming call 	–
	<ul style="list-style-type: none"> – Activate voice recognition – Interrupt voice announcement to provide a new voice command 	– Repeat the last utterance in a voice interaction
+/-	– Adjust the volume of Blue&Me™ functions: hands-free kit, message reader and media player, voice announcements	–
	– Select media player tracks	–
	<ul style="list-style-type: none"> – Scroll Blue&Me™ menu items – Scroll inbox messages 	–
OK	<ul style="list-style-type: none"> – Confirm manually selected menu option – Switch phone conversation from the hands-free phone to your mobile phone and vice versa – Select displayed message 	–
SRC	– Select audio sources (Radio, CD, CD Changer, Media Player)	–

Notes

- For many tasks, the steering wheel buttons **OK** and  can be used interchangeably, and you can use the key that is more convenient for you to press.
- For both operating modes of steering wheel buttons (short or long press), the function chosen will be activated when you release the button.

HANDS-FREE KIT QUICK REFERENCE GUIDE

To quickly get started with using the **Blue&Me™** hands-free kit with voice recognition and **Bluetooth®** wireless technology:

- Prepare your mobile phone phonebook
- Turn the ignition key to **MAR**
- Try out the voice commands
- Pair your mobile phone
- Make a phone call.
- ➔ Instructions for each of the above functions are given in the following paragraphs.

PREPARE YOUR MOBILE PHONE PHONEBOOK

Before creating a pairing relationship between your mobile phone and **Blue&Me™**, you should make sure that you have contact entries in your mobile phone phonebook so that you can use them with the hands-free phone.

➔ If your phonebook is empty, quickly create several new entries for frequently dialled phone numbers. For further details, consult your mobile phone owner's manual.

➔ To enter properly contacts in your mobile phone phonebook, refer to section **SETTING FUNCTIONS - PAIRING YOUR MOBILE PHONE**.



IMPORTANT NOTES

- The phonebook copied to **Blue&Me™** can only be used when the corresponding mobile phone is paired.
- Entries stored in SIM card or mobile phone memory can be transferred to **Blue&Me™** with different procedures, according to your mobile phone model.

TRY OUT THE VOICE COMMANDS

At each stage of your dialogue with the system, you can always use the voice command “**Help**”, to get detailed indications about the voice commands available at the current dialogue stage.

To try out the “**Help**” function, proceed as follows:

- ❑ Press the steering wheel button .
- ❑ After **Blue&Me™** plays a tone indicating that voice recognition is active, pronounce “**Help**”. **Blue&Me™** will speak the list of voice commands available.
- ❑ After the general help message is finished, pronounce “**Settings**” and then “**Help**”. **Blue&Me™** will speak again the list of voice commands available for the **SETTINGS** menu.
- ❑ You can then pronounce one of the available commands and proceed with the dialogue as you like.
- ❑ If you need further help, press  and pronounce again “**Help**”.

PAIR YOUR MOBILE PHONE

IMPORTANT Carry out this operation only with the car stopped.

To pair your mobile phone, proceed as follows:

- ❑ Press  and pronounce “**Settings**” then, at the end of the **Blue&Me™** message say “**Pairing**”.
- ❑ The system will show the phone pairing PIN number on the multifunction display. For the next two steps, consult your mobile phone owner’s manual about **Bluetooth®** pairing.
- ❑ On your mobile phone, query for devices equipped with **Bluetooth®** wireless technology (the setting on your mobile phone might be called Discover or New Device). In this list you will find “**Blue&Me**” (name identifying the **Blue&Me™** system on your car): select it.

- ❑ When prompted by the mobile phone, enter the PIN number shown on the instrument panel display using your mobile phone keypad. If pairing is successful, the system will say “**Connecting**” and at the end the display will show as confirmation message, the ID of the paired mobile phone.

It is essential to wait until you see this confirmation message on the display. Pressing  or **ESC** before the message is displayed may cancel the pairing process. If the pairing process fails, an error message will be displayed: in this event repeat the pairing procedure.

- ❑ At first pairing, **Blue&Me™** will say “**Welcome**” immediately after connecting. This message will no longer be heard at next pairing procedures.

- ❑ **Blue&Me™** will ask if you would like to copy your paired phone phonebook to **Blue&Me™**. It is recommended to copy it. To start copying the phonebook say “**Yes**”, otherwise say “**No**”.
- ❑ For certain mobile phones the phonebook is not copied automatically, in this case you must transfer the phonebook contacts using your mobile phone keypad. If **Blue&Me™** asks you to do this, then perform this procedure following the instructions specific to your mobile phone and press  when you have finished.

MAKING A PHONE CALL



Assume that “John” is one of the contacts stored in your phonebook.

To call John, proceed as follows:

- ❑ Press the steering wheel button  and pronounce “**Call John**”.
- ❑ If the name is recognized, the system will display the recognized contact’s information on the display screen.

If there is just one phone number for John in your phonebook, the system will ask if you would like to call John. To start the call say “**Yes**”, otherwise say “**No**”.

If John has several phone numbers, the system will ask which phone number you would like to call (e.g.: “**Call John (at) Work or (at) Home?**”). Answer with the type of required phone number (e.g.: “**(at) Home**”).

If John has several phone numbers but the “location” (i.e.: the type of phone number like work, home, etc.) is missing, the system will display the selected contact and a list of related phone numbers. The hands-free phone system will ask if you would like to call the phone number displayed. To respond with “yes”, pronounce “**Yes**”, otherwise pronounce “**No**”. If this is the correct contact but the wrong number, say “**Forward**” or “**Backward**” to navigate to the phone number you’d like to call. To call the displayed phone number, pronounce “**Call**”. You can also surf the phone number list manually by pressing the buttons on the steering wheel  or  until you find the required number. Now, press  or **OK** to start the call.

- ❑ To end the phone call, press  for longer than 1 second.
- 🌀 If you encounter difficulties with any of the voice recognition operations, consult section HANDS-FREE KIT - TROUBLESHOOTING.

MESSAGE READER QUICK REFERENCE GUIDE

(with compatible mobile phones only)

If your mobile phone with **Bluetooth**® wireless technology supports the message reader function, at the arrival of a new SMS text, **Blue&Me**™ plays a tone and it will ask if you would like to read it.

- pronounce “**Yes**” or press **↵** or **OK** to read the last message received
- pronounce “**No**” or press **ESC**, the system will store the message so you can read it later

For further details on the message reader SMS, refer to section “MESSAGE READER FUNCTIONS”.

➡ If you encounter difficulties with any of the message reader settings, consult section “MESSAGE READER – TROUBLESHOOTING”

MEDIA PLAYER QUICK REFERENCE GUIDE

To start playing the digital audio files stored on your USB device, proceed as follows:

- Copy tracks to your USB device (**Blue&Me**™ recognizes *.wma*, *.mp3*, *.wav* and *aac* formats for audio files and *.wpl* and *.m3u* formats for playlists).
- USB devices without USB wire: just connect the USB device (directly or by an extension lead) to the USB port on the car (see **fig. 1**).
- USB devices with USB wire: use the wire to connect the USB device to the USB port on the car (see **fig. 1**).
- Turn the ignition key to **MAR**. **Blue&Me**™ will start automatically to play your digital tracks selecting them from the library built at the moment the USB device is connected.

After **Blue&Me**™ has built the library containing your digital audio files, you can select and play tracks, albums, artists and playlists by interacting manually or verbally with **Blue&Me**™. Building the library may require a few minutes if your USB device contains several files.

- iPod player - see dedicated paragraph.
- You can also decide whether to play audio files automatically when connecting the USB device or to play them upon your command.

For further details on media player, refer to section MEDIA PLAYER FUNCTIONS.

➡ If you encounter difficulties with any of the voice recognition operations, consult section MEDIA PLAYER - TROUBLESHOOTING.

HOW TO USE Blue&Me™

CONTROLS STEERING WHEEL

Buttons on the steering wheel (see **fig. 1**) are used to perform functions on the hands-free kit, activating voice recognition, using the media player functions or selecting a **Blue&Me™** menu option.

Certain buttons have multiple functions which depend on the current state of the system.

The function chosen in response to a key press is in some cases controlled by the duration of the key press (short or long).

➡ For further information read chapter DISPLAY AND BUTTONS ON THE STEERING WHEEL.

Note

Instructions concerning manual controls are identified in the text by symbol .

VOICE COMMANDS

Voice commands can be pronounced by the driver, which does not need to change his/her normal driving position to be heard by the system, since the microphone is properly located and oriented to this purpose.

Voice commands, which are words recognized by the system, are identified as “keywords”.

The hands-free phone system recognizes and responds to a preset list of voice commands. The list of available voice commands depends on the keyword level that you are currently on. The current list is always available by pressing  and pronouncing “**Help**” or, pronouncing “**Help**” after whichever question of the system. **Blue&Me™** also recognizes personalized versions of voice commands like the name of a contact in your phonebook.

There is no voice training required for using voice commands with this system.

To issue a voice command to the system, press  and wait for the tone indicating that voice recognition is active. Then, speak the command in your natural voice at a moderate pace. When the system recognizes the command, it will acknowledge your command by speaking a response or acting on your command.



Voice commands are organized according to three increasing levels: 1st level, 2nd level and 3rd level.

When a *valid** 1st level keyword is pronounced, the system will activate 2nd level keywords; when a valid 2nd level keyword is pronounced, the system will activate 3rd level keywords.



If the user pronounces a valid 1st level keyword, then the submenu relevant to that command will remain active until a keyword leading to another level is given or the interaction is interrupted; the same rule applies for the other lower levels (2nd and 3rd level).

➡ For the list of available keywords, refer to section VOICE COMMANDS (KEYWORDS) - SUMMARY.

* *Valid* means that the keyword pronounced is included in the **Blue&Me™** “dictionary” and that can therefore be recognized by the system for the concerned level.

To repeat the last system voice announcement, press  for longer than 1 second or press shortly  and pronounce “Repeat”.

The system can issue voice announcements. A voice announcement is a spoken message initiated by the system. To cancel a voice announcement, press **ESC**, or press  and pronounce “Cancel”.

A voice interaction is a two-way communication/spoken exchange between system and user. To initiate a voice interaction, press  and issue a command. To interrupt a conversation and start a new one, press  at any time during the conversation and pronounce a vocal command.

To stop an ongoing interaction press **ESC**. You will hear a tone indicating when voice recognition is deactivated.



The hands-free kit help option can speak the list of commands available to you at any time, depending on the keyword level that you are currently on. To use the help system, say “**Help** Listen to the list of currently available commands and decide on which command you’d like to issue to the system.

Adjust the volume of phone calls to a level that is comfortable and safe while the car is in motion. To adjust the default volume of **Blue&Me™**, see paragraph “EXTERNAL AUDIO VOL function” in the sound system owner handbook. To temporarily adjust the volume of the current phone call, press **+** or **-** or adjust the position of the radio knob. After the phone call is disconnected, the volume will revert back to the original level.

You can press **+** or **-** also to adjust the volume of the current **Blue&Me™** voice announcement.



Please remember that to interrupt a voice announcement, you can always press  at any time during a voice interaction and give a new voice command.

Notes

- Instructions concerning voice commands are identified in the text by symbol .
- After you press , if you do not issue a voice command within a few seconds, the system will prompt you to pronounce a voice command. If you do not respond, then voice recognition shuts off. It is the same case with not responding to a question during a voice interaction. You will hear a tone indicating when voice recognition is deactivated.
- When the system fails to recognize your voice command, it will give you another opportunity to re-pronounce the voice command. If you are unsure of whether the voice command is appropriate for the given context, pronounce “**Help**”.

Using voice recognition

The voice recognition system may occasionally misrecognize a voice command. To ensure that your voice commands are always recognized by the system, use the following guidelines:

- After pressing , pronounce the voice command after the system plays a tone indicating that voice recognition is active.
 - After the system asks a question, wait for one second before pronouncing the response to ensure that voice recognition is active.
 - If you want to pronounce a command without waiting that the system has finished its announcement or question, you can press again shortly  to interrupt what the system is saying and pronounce your command.
 - Speak at a normal volume.
- Pronounce words clearly, in your natural voice at a moderate pace, without stops.
 - If possible, try to minimize background noise in the car.
 - Ask the other passengers to keep silent while you are pronouncing voice commands to prevent misunderstanding since the system could recognize other words (in addition to or different from your voice command) if several people are speaking.
 - If your car has a convertible top, close it before using voice recognition.

Notes

As concerns countries where the version in native language is not available, voice recognition of the different commands and phonebook contacts could be difficult. You are therefore recommended to adopt a pronunciation/accents meeting the language present on **Blue&Me™**.

To change the voice recognition language contact Fiat Dealership or consult the dedicated site at www.fiat.com.

DISPLAY

The different **Blue&Me™** Main Menu options are displayed on the instrument panel multifunction display (see **fig. 1**).

The display shows the following information:

- Status information for the **Bluetooth®** wireless technology-enabled mobile phone.
-  indicates that **Blue&Me™** is currently connected with a **Bluetooth®** wireless technology-enabled mobile phone.
- NO BLUETOOTH** - the connection is disconnected (versions with multifunction display).

- Name of your current mobile phone carrier (“- - - - -” displayed if not available).
- Info about message received, message sender phone number or name (if stored in the phonebook).
- Data concerning the track being played by the media player.
- Current **Blue&Me™** information or current menu option.

AUDIO

Blue&Me™ uses your in-car audio equipment to deliver audio output (hands-free phone conversation, media player, voice announcements and tone signals). For this purpose, the current audio program is muted for the time needed.

You can always adjust the audio volume either through the radio or the steering wheel controls.

When the audio system is used by **Blue&Me™**, the radio display will show dedicated messages.

Blue&Me™ FUNCTION MENU

Blue&Me™ Main Menu displays options within a structured list. Each option (item) in the menu can be viewed on the instrument panel multifunction display. Available options enable to activate the different functions or to change the settings of your **Blue&Me™** system.

The Main Menu includes the following options:

- ❑ **LAST CALLS** - this submenu allows you to view a list of the recent calls made or received. This list is either downloaded from your mobile phone memory, or accumulated via use of the hands-free phone, or both.
- ❑ **PHONEBOOK** - this submenu allows you to view the phone numbers in your phonebook and to select one to dial. If there is a large amount of entries in your phonebook, then the items will be contained in groups within alphabetical submenus indicating the contacts within that group. The number of contacts within a group depends on the amount of entries in your phonebook.

❑ MESSAGE READER

(with compatible mobile phones only) - This submenu enables to read the last message received, to call the message sender or to delete the last message received. It is possible to store up to 20 received messages in the dedicated inbox and to play them later, to call the message sender or to delete the messages. It is possible to select notification signals for the arrival of a new SMS text.

- ❑ **MEDIA PLAYER** - this submenu allows to scroll the digital audio tracks in the library by folder, artist, genre, album or by playlist. This sub-menu is to be used to select and play tracks.

iPod player - see dedicated paragraph.

- ❑ **SETTINGS** - this submenu allows you to perform tasks such as managing your phonebook entries, creating a pairing relationship, or setting a connection ID.

Launching the Main Menu

To launch the **Blue&Me™** Main Menu, press **↵** you can then interact with the system through the buttons on the steering wheel.

Navigating the menu options

To navigate through the items in a menu, press **↑** or **↓**.

When the number of characters in a display message is too long for the allowable number of display characters, the text in the display message will be cut to fit the display size.

To select the option shown on the display, press **OK** or **↵**.

To quit the selected option or to exit a submenu, press **ESC**.

HANDS-FREE KIT FUNCTIONS

Blue&Me™ lets you make and receive phone calls on your **Bluetooth®** wireless technology-enabled mobile phone using voice commands (keywords) or steering wheel buttons.

By using voice commands, you can make calls to people in your phonebook by pronouncing their first and/or last name, or you can make phone calls to numbers not stored in your phonebook by pronouncing the digits of the phone number or call the last message sender.

By using steering wheel buttons, you can make phone calls to people in your phonebook or call history list by selecting the associated item in the **LAST CALLS** or **PHONEBOOK** submenus.

In addition, you can use other calling features such as responding to incoming calls, redial, callback, call waiting, read a message or delete it.

➔ If you encounter difficulties with any of the voice recognition operations, consult section **HANDS-FREE KIT - TROUBLESHOOTING**.

Notes

Before you can make and receive phone calls using the hands-free kit, you must create a pairing relationship for your mobile phone.

➔ For further information read chapter **SETTING FUNCTIONS – PAIRING YOUR MOBILE PHONE**.

To activate the hands-free kit, the ignition key shall be at **MAR**.

If during a phone call you turn the ignition key to **STOP**, you can continue your conversation through the hands-free kit for other 15 minutes.

MAKING A PHONE CALL

You can make a phone call using one of the following methods:

Calling a contact in your phonebook

Dialling a phone number using voice commands

Dialling a phone number using the mobile phone keypad

Calling a phone number using call history (last calls)

Call the sender of a received SMS message

➔ For further information refer to chapter **FUNCTIONS OF SMS MESSAGES READER**, paragraph **SMS MESSAGES MANAGEMENT**

Calling a contact in your phonebook

It is a requirement that you create a pairing relationship and download your mobile phone phonebook to the hands-free phone system to use this dialing feature.



To call a contact in your phonebook using manual interaction, proceed as follows:

Press **↶** to open the Main Menu. Select **PHONEBOOK** and then press **OK** or **↶**.

Press **↑** or **↓** to select the alphabetical grouping which your contact's name belongs to, press **OK** or **↶** and then select the required contact.

If the contact has just one phone number, press **OK** or **↶** to start the call.

If the contact has multiple phone numbers, press **OK** or **↶** to view the different phone numbers and then select the required one by **↑** or **↓** and press **OK** or **↶** to start the call.

To end the phone call, press **↶** for longer than 1 second.



Or, using voice interaction:

Assume you would like to call the contact "John" in your mobile phone phonebook.

Press **⊞** and pronounce "**Call John**" or "**Call John (on/at) Mobile**" (in the previous statement, the keyword "**Mobile**" represents the type of phone number you would like to call. The phone number type can either be "**(at) Home**", "**(at) Work**", or "**(on/at) Other**").

If the name is recognized, the system will display the recognized contact's information (John, in the example) on the display screen.

If John has just one phone number, the system will ask if you would like to call John. To start the call say "**Yes**", otherwise say "**No**".

If John has several phone numbers, the system will ask which phone number you would like to call (e.g.: "Call John (at) Work or (at) Home?"). Answer with the type of required phone number (e.g.: "**(at) Home**").

If John has several phone numbers but the "location" (i.e.: the type of phone number like work, home, etc.) is missing, the system will display the selected contact and a list of related phone numbers.

To call the displayed phone number, pronounce "**Call**".

If the contact is correct but the phone number is wrong, you can surf the phone number list manually by pressing **↑** or **↓**. When you find the required number, press **↶** or **OK** to start the call.

To end the phone call, press **↶** for longer than 1 second.

Practical hint

When you call a contact with multiple phone numbers, use the "at location" portion of the voice command (e.g.: "**(at) Home**", "**(at) Work**", "**(on/at) Mobile**"). This will shorten the amount of steps required to make the phone call.

Dialling a phone number using voice commands

 To dial a phone number using voice interaction, proceed as follows:

Press  and pronounce “**Dial**”.

The system will respond with “**Number, please**”.

Pronounce the phone number as a sequence of single digits (e.g.: “0”, “1”, “2”, “3”, “4”, “5”, “6”, “7”, “8”, “9”, “+” (plus), “#” (pound) or “*” (star)).

For example, 0113290103 has to be pronounced as: “zero, one, one, three, two, nine, zero, one, zero, three”.

The system will repeat the complete phone number and display it.

If the number is complete, pronounce “**Dial**”. If you have not finished speaking the phone number, then pronounce the remaining digits and then pronounce “**Dial**”.

The system will start the call to the displayed phone number.

To end the phone call, press  for longer than 1 second.

You can pronounce the sequence of phone number digits in “digit groups” which allows you to verify the recognized number in several small portions. Digit groups are created by the pauses you use while pronouncing the sequence of digits. If you pause after pronouncing several digits, a digit group is created. The system will repeat the recognized digits.

If the spoken digits are correct, you can continue pronouncing the phone number. If the spoken digits are incorrect, you can delete the digit group by pronouncing “**Delete**”. The system will delete the last group of numbers and display the partially-dialled phone number. Then, you can re-pronounce the digit group and also the remaining phone number digits.

To cancel the phone call, pronounce “**Cancel**”.

To cancel the phone call and start dialling again, pronounce “**Start over**”.

To ask the system to repeat the recognized phone number, pronounce “**Repeat**”. If no phone number was dialled, the system says “**No number available**”.

If the repeated phone number is correct, pronounce “**Dial**” to start the call.

Note

When dialling a phone number by voice commands, it is essential to minimize background noise in the car and to ask the other passengers to keep silent while you are speaking digits. Since the system is of the speaker independent type it can recognize also other voices; there is therefore the risk that some numbers are accidentally recognized, added to correct numbers or not recognized.

Dialling a phone number using the mobile phone keypad



Alternatively, you can dial a phone number using your mobile phone keypad and then continue your conversation using the hands-free phone system.

It is a requirement that you create a pairing relationship and that the mobile phone is within range of the hands-free phone system of your car.

To dial a phone number using your mobile phone keypad, proceed as follows:







- Dial the phone number on your mobile phone keypad and connect the phone call following the procedure required by your mobile phone.
- Conduct the conversation using the hands-free phone system.
- To end the phone call, press  for longer than 1 second, or end the phone call from your mobile phone keypad.

Calling a phone number using call history (last calls)

LAST CALLS option is a list of the recent calls made or received. It can consist of up to ten incoming calls, up to ten outgoing calls and up to five missed calls.



To dial a phone number using manual interaction, proceed as follows:

- Press  to open the Main Menu.
- Select **LAST CALLS** and then press **OK** or .
- The system will present a list of phone numbers. Use  or  to select the required phone number. Then press **OK** or  to start the call.
- To end the phone call, press  for longer than 1 second.



Or, using voice interaction:

To call back the last incoming phone number, press  and pronounce **“Callback”**.

The system will display information about the last caller and ask if you would like to call back this contact. To respond with “yes”, pronounce **“Yes”**, otherwise say **“No”**.

To redial the last phone number you called, pronounce **“Redial”**. The system will display information about the last contact you called and will ask if you would like to redial this phone number. To redial the last phone number called, say **“Yes”**, otherwise say **“No”**.

INCOMING CALLS

With the hands-free phone system you can respond to incoming phone calls using steering wheel buttons. When a phone call is received, the system will display information about the caller's identity if available.

The incoming phone call will have customized ring tone (if this function is available on your mobile phone).

Answering a phone call

- To answer the phone call, press **↵**.
- To end the phone call, press **↵** for longer than 1 second.

Rejecting a phone call

- To reject the phone call, press **↵** for longer than 1 second.

Ignoring a phone call

- To ignore the phone call and mute the phone call ring tone, press **ESC**.

Answering an incoming phone call during an active phone conversation

To answer an incoming phone call while another phone conversation is active, press **↵**. The system will switch to the incoming phone call and put the current phone conversation on hold.

Note

Certain mobile phones support the ability to transmit your contacts' ring tones to the hands-free phone system and play customized ring tones for incoming phone calls. In this case the incoming phone calls will have your mobile phone customized ring tones.

MANAGING PHONE CALLS

Transferring a phone conversation from your mobile phone to the hands-free phone system

If you enter the car during a phone conversation from your mobile phone and you want to continue the conversation using the car hands-free phone system, you can transfer the phone conversation to it.

Proceed as follows:

- Get into the car and turn the ignition key to **MAR**, to activate the hands-free phone system.
- The system will send a message to your mobile phone offering hands-free phone support.
- To transfer the conversation to the hands-free phone, enter the information required by your mobile phone. (This process is different for each mobile phone).
- The phone conversation is transferred to the system.

Transferring a phone conversation from the hands-free phone to your mobile phone

To transfer a phone conversation from the hands-free phone to your mobile phone, press **OK**.

You can talk on your mobile phone and still use buttons on the steering wheel. Specifically, you can press ↵ to switch between two phone calls on your mobile phone, or press ↵ for longer than 1 second to end the phone conversation.

Putting a phone call on hold

To put a phone call on hold and disable the microphone so that you can talk without being listened to by the caller, press **ESC**.

CONFERENCE CALL FUNCTION (only with Bluetooth® phones supporting this function)

With the Conference Call function you can call another contact while you are engaged in a phone conversation yet. In this way you can speak with both contacts at the same time.

To start a Conference call while you are still engaged in a phone conversation, call the second required contact as described in section MAKING A PHONE CALL.

When Conference Call option is active the display will show “**CONFERENCE**”.

To end both calls, press button ↵ for long

MESSAGE READER FUNCTIONS

(with compatible mobile phones only)

If your mobile phone with **Bluetooth**[®] wireless technology supports the message reader function, at the arrival of a new SMS text, **Blue&Me**[™] plays a tone and it will ask if you would like to read it (according to set signal types).

To consult the list of mobile phones and functions supported, consult the dedicated website www.fiat.com **Blue&Me**[™] or Customer Services on 00800.3428.0000.

➔ For information on signal types refer to paragraph **Signal types**.



If you want **Blue&Me**[™] Nav to read the SMS message received by manual interaction press **OK** or ↵. The message will be read taking into account any abbreviation or emoticon contained in the text.

Otherwise press **ESC**. **Blue&Me**[™] will not read the message but it will store it so you can read the message later (for further information refer to paragraph **How to read the last SMS text received**).



Or, using voice interaction: if you pronounce “**Yes**”, **Blue&Me**[™] will read the message, taking into account any abbreviation contained in the text, otherwise say “**No**”, the system will store the message so you can read it later (for further information refer to paragraph **How to read the last SMS text received**).

HOW TO READ THE LAST SMS TEXT RECEIVED

After receiving a message, **Blue&Me**[™] will store it (both read or not read message) in the inbox (refer to paragraph **Inbox**).



To read the last message received, open **Blue&Me**[™] Main menu and select option **MESS. READER**, then press **OK** or ↵.

Select the option **READ LAST** and press **OK** or ↵, **Blue&Me**[™] will read the last message received.



Or, using voice interaction:

Press **Windows** and pronounce “**Read last one**”, **Blue&Me**[™] will read the text of the last message received.

INBOX

Blue&Me™ will store up to 20 received messages (in the event of linked messages, the number of stored messages could be lower) when your mobile phone is paired with **Bluetooth®**. When the inbox is full, the new incoming message will delete the oldest message received (also if not read yet). It is also possible to delete just one message or to delete the entire inbox (refer to paragraph MANAGING MESSAGES).

 To read a particular message stored in the inbox, open the **Blue&Me™** Main menu and select the option **MESS. READER**, then press **OK** or ↵.

Select option **INBOX**, then press **OK** or ↵. Scroll stored messages and select the required one, the system will display the SMS text sender's data, if available. Select **READ** and press **OK** or ↵, **Blue&Me™** will read the selected message.



Or, using voice interaction:

Press  and pronounce "**Message reader**", after the acoustic signal pronounce "**Inbox**"; **Blue&Me™** will display the first message contained in the inbox (and also the phone number of the SMS text sender, if stored in the phonebook).

To scroll the **Inbox** pronounce "**Previous**" or "**Next**"; when the required message is displayed, say "**Read**", **Blue&Me™** will read the selected message.

Pronounce "**Delete**" to delete the selected message.

MANAGING MESSAGES

For every message received, **Blue&Me™** enables to:

- read it
- call directly the sender
- delete it



To do this when reading the message open the **Blue&Me™** Main menu and then press buttons **OK** or ↵ to select the required option.



Or, using voice interaction:

Press  and pronounce "**Read**" or "**Call**" or "**Delete**", the system will select the required option.

DELETING ALL MESSAGES

Blue&Me™ can store max 20 messages, a new incoming message will delete the oldest one received from the inbox. All messages stored by **Blue&Me™** can be deleted by one single command.



To delete all messages, open the **Blue&Me™** Main menu and select **DELETE ALL**, then press **OK** or **↵**, the system will ask **DEL. MESS.?**, press **OK** or **↵** to delete all messages, otherwise press **ESC**.



Or, using voice interaction:

Press **⏏** and pronounce “**Message reader**”.

After the acoustic signal say “**Delete all**”; **Blue&Me™** will ask “**Delete all messages from the vehicle now ?**”, say “**Yes**” to delete all messages, otherwise say “**No**”.

SIGNAL TYPES

With the **Blue&Me™** message reader it is possible to set three notification signals for the arrival of a new SMS text:

☐ **VIS.+ACOUST.:**

Blue&Me™ will warn you of a new incoming message through a visual signal on the instrument panel display and through an acoustic signal. **Blue&Me™** will also ask if you would like to read the message.

☐ **VIS. SIGNAL:**

Blue&Me™ will warn you of a new incoming message through a visual signal on the instrument panel display. The message received can also be read later (see paragraphs HOW TO READ THE LAST SMS TEXT RECEIVED and INBOX).

☐ **READER OFF:**

Blue&Me™ deactivates the **Message reader**; a new incoming message will not be signalled and will not be transmitted to the system.



Open the **Blue&Me™** Main menu, select the option **MESS. READER**, and then press **SRC/ OK** or **↵**. Select the option **SIGNAL TYPE** and scroll the three available options using buttons **↑** or **↓**, select the required option and then press **OK** or **↵**.



Or, using voice interaction:

Press **⏏** and pronounce “**Message reader**”, after the acoustic signal say “**Signal type**”; **Blue&Me™** will list the available options and then you can select the required one by pronouncing “**Reader off**” or “**Visual and acoustic signal**” or “**Visual signal only**”.

MEDIA PLAYER FUNCTIONS

The **MEDIA PLAYER** menu enables the following:

- to display tracks stored on your USB device
- to play audio files stored on your USB device.

Note

Before using the player, read the section on COMPATIBLE USB STORAGE DEVICES or on using an iPod to check that your USB memory device is compatible with **Blue&Me™**.

HOW TO CONNECT THE USB DEVICE TO Blue&Me™

To connect your USB device to **Blue&Me™**, proceed as follows:

- Copy the tracks on your USB device. For further information, see “TECHNOLOGIES COMPATIBLE WITH **Blue&Me™**”.
- USB devices without USB wire: just connect the USB device (directly or by an extension lead) to the USB port on the car (see **fig. 1**).
- USB devices with USB wire: use the wire to connect the USB device to the USB port on the car (see **fig. 1**).
- Turn the ignition key to **MAR**. **Blue&Me™** will start automatically to play your digital tracks selecting them from the library built at the moment the USB device is connected.
- If **AUTOPLAY** is set to “**ON**”, **Blue&Me™** will start playback automatically.

➡ For further information read chapter **SETTINGS FUNCTION - MEDIA PLAYER**.

When building the media library is over, it will be possible to use **Blue&Me™** to select and play tracks.

HOW TO MANAGE THE MEDIA LIBRARY

With the media player you can select the audio files stored on your USB device, using voice commands or steering wheel buttons.

You can scroll audio files by folder, artist, genre, album or playlist and then select the required category using voice commands. After selecting the required category, select the required file using manual controls.

Enter track data (e.g.: title, artist, album, genre) for surfing your media library friendly.

Note

Not all formats require to enter media info. Formats *.mp3* and *.wma*, *.aac* recognized by **Blue&Me™** require media info whereas *.wav* not. If no media info is entered, audio files can only be selected by folder.

➤ For further details, refer to section PRACTICAL HINTS FOR USING THE MEDIA PLAYER.

Selection by folder

Track folders on your USB device are displayed in the **FOLDERS** menu.

 To select tracks through manual interaction, proceed as follows:

Launch the Main Menu and select **MEDIA PLAYER**, then press **OK** or ↵.

Select **FOLDERS**, then press **OK** or ↵.

Scroll folders. To play all folders, select **PLAY ALL** and then press **OK** or ↵. To display folder tracks, press **OK** or ↵.

Scroll the selected folder tracks. To play the required track, select the title and then press **OK** or ↵.



Or, using voice interaction:

Press  and pronounce “**Folders**”.

Scroll folders. To play all folder, select **PLAY ALL** and then press **OK** or ↵. To display folder tracks, press **OK** or ↵.

Scroll the selected folder tracks. To play the required track, select the title and then press **OK** or ↵.

For further details on **FOLDERS**, menu customization, see section PRACTICAL HINTS FOR USING THE MEDIA PLAYER.

Selection by artist

 To select the tracks of a special artist using manual interaction, proceed as follows:

Launch the Main Menu, select **MEDIA PLAYER**, and then press **OK** or ↵.

Select **ARTISTS** and then press **OK** or ↵.

Scroll artists. To select the required artist, press **OK** or ↵.

Scroll the artist's albums. To play all the albums of the required artist, select **PLAY ALL** and press **OK** or ↵.

To play an album, select the required album and then press **OK** or ↵.

To play a track, select the title and then press **OK** or ↵.



Or, using voice interaction:

Press  and pronounce "**Artists**".

Scroll the artist's albums. To play all the albums of the required artist, select **PLAY ALL** and then press **OK** or ↵. To play an album, select the required album and then press **OK** or ↵.

To play a track, select the title and then press **OK** or ↵.

Note

If your USB device contains many audio files, the **ARTISTS** menu can be subdivided into alphabetical sub-menus. Alphabetical sub-menu can display just the first letter of the tracks it contains (e.g.: A-F), or it can display the first two letters (e.g.: Aa-Ar).

Selection by genre



To select the tracks of a special genre using manual interaction, proceed as follows:

Launch the Main Menu, select **MEDIA PLAYER**, and then press **OK** or ↵.

Select **GENRES** and then press **OK** or ↵.

Scroll genres. To play all the tracks of the displayed genre, press **OK** or ↵.



Or, using voice interaction:

Press  and pronounce "**Genres**".

Scroll genres. To play all the tracks of the displayed genre, press **OK** or ↵.

Note

If your USB device contains many audio files, the **GENRES** menu can be subdivided into alphabetical sub-menus. Alphabetical sub-menu can display just the first letter of the tracks it contains (e.g.: A-F), or it can display the first two letters (e.g.: Aa-Ar).

Selection by album



To select an album using manual interaction, proceed as follows:

Launch the Main Menu, select **MEDIA PLAYER**, and then press **OK** or ↵.

Select **ALBUMS** and then press **OK** or ↵.

Scroll albums. To select the displayed album, press **OK** or ↵.

Scroll the album tracks. To play all the tracks in the album, select **PLAY ALL** and press **OK** or ↵. To play an album, select it and then press **OK** or ↵.

To play just one track, select the track title and press **OK** or ↵.



Or, using voice interaction:

Press  and pronounce “**Albums**”.

Scroll albums. To select the displayed album, press **OK** or ↵.

Scroll the album tracks. To play all the tracks in the album, select **PLAY ALL** and press **OK** or ↵.

To play just one track, select the track title and press **OK** or ↵.

Note

If your USB device contains many audio files, the **ALBUMS** menu can be subdivided into alphabetical sub-menus. Alphabetical sub-menu can display just the first letter of the tracks it contains (e.g.: A-F), or it can display the first two letters (e.g.: Aa-Ar).

Selection by playlist

Playlists stored in your USB device can be displayed with the **PLAYLISTS** menu.



To select a playlist using manual interaction, proceed as follows:

Launch the Main Menu, select **MEDIA PLAYER**, and then press **OK** or ↵.

Select **PLAYLISTS** and press **OK** or ↵.

Scroll playlists. To play the displayed playlist, press **OK** or ↵.



Or, using voice interaction:

Press  and pronounce “**Playlists**”.

Scroll playlists. To play the displayed playlist, press **OK** or ↵.

For further details on how to build playlists, refer to section **PRACTICAL HINTS**.

PLAYING AUDIO TRACKS

Shuffle playback of the whole media library

Option “**PLAY ANYTHING**” shall be used to play quickly the whole content of your media library at random.

 To start “**PLAY ANYTHING**” using manual interaction, proceed as follows:

Launch the Main Menu, select **MEDIA PLAYER**, and then press **OK** or ↵.

Select **PLAY ANYTHING** and press **OK** or ↵.

 Or, using voice interaction:

Press  and pronounce “**Play anything**”.

For further details on digital audio files playback, refer to section “DIGITAL AUDIO SELECTION”.

Now playing (track data)

With the **NOW PLAYING** option you can display current track data for 15 seconds.

 To start this option using manual interaction, proceed as follows:

Launch the Main Menu, select **MEDIA PLAYER**, and then press **OK** or ↵.

Select **NOW PLAYING** and then press **OK** or ↵.

 Or, using voice interaction:

Press  and pronounce “**Now playing**”.

Note

When the playback of a digital audio track is started, the relevant track data will be automatically displayed for 15 seconds.

Audio play

 To start playing an audio file using manual interaction, proceed as follows:

If “**AUTOPLAY**” option is on, connect your USB device to **Blue&Me™**: track playback will start automatically.

 **SETTINGS FUNCTION - MEDIA PLAYER.**

You can also select the required audio file and then press **OK** or ↵ to start playing it.

 Or, using voice interaction:

Press  and pronounce “**Play anything**”.

Pause

To pause the track being played: Press  /**ESC** or button **MUTE** on sound system front panel.

Play

To resume playback of the paused track: Press **ESC** or button **MUTE** on sound system front panel.

Stop

To stop playing a track: Pronounce “**Stop**”.

Next track

 To play next track using manual interaction, proceed as follows:

While playing a digital track press .

 Or, using voice interaction:

While playing a digital track press  and pronounce “**Next**”.

Previous track

 To play the previous track using manual interaction, proceed as follows:

While playing a track press .

 Or, using voice interaction:

While playing a digital track press  and pronounce “**Previous**”.

Note

If “Previous track” (manual or voice) command is given after playing the first 3 seconds of the track, the track will be played again. If it is given within the first 3 seconds, the previous track will be played.

Changing audio source

To change the active audio source (Radio, CD, CD Changer, multimedia player), press **SRC** or the keys on the radio front panel (see relevant manual).

Note

For further details on voice commands (keywords) to be used with the media player, refer to section VOICE COMMANDS (KEYWORDS) - SUMMARY.

To manage audio files from iPod or iPhone devices, refer to "TECHNOLOGIES COMPATIBLE WITH **Blue&Me**™”.

PRACTICAL HINTS FOR USING THE MEDIA PLAYER

Scrolling

- To optimize scrolling of the **FOLDERS** menu, organize folders on your USB device before connecting it to **Blue&Me™**. To facilitate and to optimize **FOLDERS** menu selection, organize your tracks in folders with prompt names for you.

Organizing media files

- In order to make the musical selection on **Blue&Me™**, based on predefined selection criteria (author, album, type, etc.) information contained in multimedia files must be catalogues and updated. To update file data, follow the instructions given on your software instruction manual.
- If certain items in your library have no Artist, Album, Title and Genre, **Blue&Me™** will show **UNKNOWN** in **ALBUMS** and **GENRES** menus. To enter the required data, follow the instructions given on your software instruction manual.

Building the media library on Blue&Me™

- Building the media library may require a few minutes. If the time required is excessive, you can intervene by reducing the number of audio files stored on your USB device.
- While building the library, it is however possible to play a selection of tracks. **Blue&Me™** will build the library while playing music.

Building playlists for Blue&Me™

For building *.m3u* or *.wpl* playlist for **Blue&Me™** using Microsoft® Windows Media® Player, proceed as follows:

- Copy required tracks into a new folder or to your USB memory device.
- Open Microsoft® Windows Media® Player. Select **File, Open** from the menu.
- Scroll the content of the USB device connected to your computer and select the audio files to be entered in the playlist.
- Click on **Open**.
- Move to “**File**” and select “**Save Now Playing List As**” ... In field “**File Name**” enter the required name and in field “**Save as type**” set the type: *.wpl* or *.m3u*.
- Click on **Save**.

When the above steps are over, the new file *.m3u* or *.wpl* will be built.

SETTINGS FUNCTIONS

The **SETTINGS** menu enables you to perform the following functions:

- Pairing a mobile phone
- Managing user data
- Media player settings
- Advanced Options.

To perform functions and adjustments in the **SETTINGS** menu, you may use buttons on the steering wheel or voice commands at car standstill. When the car is moving, you can use voice commands only. Instructions are provided for both methods.

➔ If you encounter difficulties with any of the **Blue&Me™** settings, consult section **TROUBLESHOOTING**.

PAIRING A MOBILE PHONE

Before you can use your mobile phone with the hands-free phone function on your car, you must create a pairing relationship between the mobile phone and the hands-free phone system.

During the pairing procedure, the hands-free phone system attempts to detect a phone equipped with **Bluetooth®** wireless technology within range, and then establishes the connection using a Personal Identification Number (PIN). After a pairing relationship is established, you can use the hands-free phone system to make and receive phone calls, and do other operations via your wirelessly-connected mobile phone.

IMPORTANT The mobile phone pairing PIN number is a special PIN generated randomly at each new pairing and used just for this operation. It is not your SIM PIN and therefore it is not required to store or to keep it in mind; losing it will not impair the hands-free phone system operation.

The pairing procedure will only need to be performed once for your mobile phone. After this procedure **Blue&Me™** will automatically connect to your phone each time you get into the car and turn the ignition key to **MAR**.

You can create a pairing relationship using the **PAIRING** option in the **SETTINGS** menu.



To create a pairing relationship using manual interaction, proceed as follows:

Press **↶** to open the Main Menu, then select **SETTINGS** by pressing **OK** or **↶**.

Select **PAIRING** and then press **OK** or **↶**. The system will start the pairing procedure.

The system shows the mobile phone pairing PIN on the instrument panel display and repeats it. Please note that this is a PIN used just for this operation, it is not your SIM PIN.

For the next two steps, consult your mobile phone owner's manual about **Bluetooth®** pairing.

On your mobile phone, query for devices equipped with **Bluetooth**® wireless technology that are within range (this option on your mobile phone might be called Discover, New Device, etc.). View the list of **Bluetooth**® wireless technology enabled devices and select “**Blue&Me**” (item that identifies **Blue&Me**™ on your car).

When prompted by the mobile phone, enter the PIN number shown on the instrument panel display. If pairing is successful, the system will say “**Connecting**” and then the display will show the paired mobile phone ID.

It is of vital importance to wait until this confirmation message is displayed since pressing ↵ or **ESC** at this time may cancel the pairing process. If pairing fails, an error message will be displayed and the pairing procedure shall be repeated.

At first pairing, the system will say “**Welcome**” immediately after connecting. This message will no longer be heard at next pairing procedures.

The system asks if you would like to copy your paired phone phonebook. It is recommended to copy it. To start copying the phonebook, press **OK** or ↵; otherwise press **ESC**. You can download your phonebook at a later time using the menu option **SETTINGS, USER DATA, PHONEBOOK**.

For certain mobile phones the phonebook is not copied automatically, in this case you must send the contacts in your mobile phone phonebook to the hands-free phone system using your mobile phone keypad. If the hands-free phone system asks you to do this, then perform this procedure following the instructions specific to your mobile phone and press ↵ when you have finished.



Or, using voice interaction:

Press  and pronounce “**Settings**”, wait shortly for feedback and then pronounce “**Pairing**”.

The system shows the mobile phone pairing PIN on the instrument panel display and repeats it.

For the next two steps, consult your mobile phone owner’s manual about **Bluetooth**® pairing.

On your mobile phone, query for devices equipped with **Bluetooth**® wireless technology that are within range (this option on your mobile phone might be called Discover, New Device, etc.). View the list of **Bluetooth**® wireless technology enabled devices and select “**Blue&Me**” (item that identifies the hands-free kit in your car).

When prompted by the mobile phone, enter the PIN number shown on the instrument panel display using your mobile phone keypad. If pairing is successful, the system will say “**Connecting**” and then the display will show the paired mobile phone ID.

It is of vital importance to wait until this confirmation message is displayed since pressing **** or **ESC** at this time may cancel the pairing process. If pairing fails, an error message will be displayed and the pairing procedure shall be repeated.

At first pairing, the system will say **“Welcome”** immediately after connecting. This message will no longer be heard at next pairing procedures.

The system asks if you would like to copy your paired phone phonebook. It is recommended to copy it. To start copying the phonebook, pronounce **“Yes”**; otherwise say **“No”**.

For certain mobile phones the phonebook is not copied automatically, in this case you must send the contacts in your mobile phone phonebook to the hands-free phone system using your mobile phone keypad. If the hands-free phone system asks you to do this, then perform this procedure following the instructions specific to your mobile phone and press **** when you have finished.

Practical hints

To improve both the voice recognition of your phonebook entries and **Blue&Me™** pronunciation accuracy when repeating the entries, please try to enter contact entries and memorize them using the following criteria:

- Avoid abbreviations.
- Write foreign names according to the way in which they are pronounced according to the rules of the **Blue&Me™** language set on your car. For example, enter “Tanja” as “Tanya”, to improve recognition accuracy and also to obtain the correct pronunciation by the system.
- When adding or editing contact entries, insert the appropriate accent marks when the name requires these marks to be properly pronounced and recognized by the system. For example enter “Nicolo Rebora” as “Nicolò Rébora” to obtain the correct pronunciation.
- When adding or editing contact entries, bear in mind that certain isolated block letter may be read as Roman numerals (e.g.: V may be read as fifth).
- When calling contacts by voice, do not include the middle names or middle initials of your contacts.

Notes

- You are only required to pair your mobile phone a single time.
- You can pair up to five mobile phones, to be used one at a time.
- On your paired mobile phone, the **Bluetooth®** setting must be turned on in order to connect your mobile phone with **Blue&Me™**.
- Before transferring your mobile phone contacts to the hands-free system, make sure that each contact first and last name is unique and distinctly recognizable so that the voice recognition system will function properly.
- The system will download only valid contact entries. A valid contact entry must include both a name and at least one phone number.

- ❑ If you would like to re-pair your mobile phone, delete the old pairing relationship first. During this operation all user data will be deleted. To delete the old pairing relationship, use the menu option **USER DATA, DELETE USERS**. On your mobile phone, delete “Blue&Me” from the list of **Bluetooth**® devices following the specific instructions for your mobile phone (refer to your mobile phone owner’s manual).
- ❑ If you download a phonebook with a contacts list including more than 1000 contacts, the system may operate slower than expected and voice recognition of the names in your phonebook may degrade.
- ❑ If the pairing relationship is accidentally deleted, the pairing procedure shall be repeated.

MANAGING USER DATA

You can make adjustments to the user data used by the hands-free phone system. Specifically, you can reset all user data for paired phones, delete the phonebook or reset both user data and phonebook downloaded. In this way the system is brought back to initial conditions. You can also download either the phonebook or single contacts from your mobile phone to the system, if you chose not to download the phonebook during the phone pairing procedure. You can make adjustments to the user data used by the system using the option **USER DATA**.



To open the **USER DATA** menu using manual interaction, proceed as follows:

Press to open the Main Menu, then select **SETTINGS** by pressing **OK** or .

Select **USER DATA** and then press **OK** or .



Or, using voice interaction:

Press and pronounce “**Settings**” wait shortly for feedback and then pronounce “**User data**”.

In the **USER DATA** menu you can perform the functions described below.

Delete user data

In the **USER DATA** menu you can delete the pairing relationships. After you delete the pairing relationship, you cannot use an unpaired phone with the hands-free phone system, nor its phonebook, until you create a pairing relationship for it. Always remember that this operation deletes all the pairing relationships.

 To delete user data using manual interaction, proceed as follows:

Select **DELETE USERS** and then press **OK** or ↵.

The system will display the message **DELETE USERS?**. To confirm, press **OK** or ↵.



Or, using voice interaction:

Press , pronounce “**Settings**”, wait shortly for feedback and then pronounce “**Delete users**”.

The system will ask “**Delete all paired users?**”. To confirm, pronounce “**Yes**”.

Notes

- Always remember that, if a mobile phone is paired with the system while another phone is connected yet, connection with the current phone is interrupted to establish the connection with the new phone.
- It is not possible to delete a pairing, unless it is the only one.
- Deleting all paired users will entail a new pairing procedure.

Delete the phonebook

In the **USER DATA** menu you can delete the phone that was downloaded to the system.



To delete the phonebook using manual interaction, proceed as follows:

Select **DEL. PHONEBOOK** and then press **OK** or ↵.

The system will display the question **DEL. PHONEBOOK?**. To confirm, press **OK** or ↵.



Or, using voice interaction:

Press , pronounce “**Settings**” wait shortly for feedback and then pronounce “**Delete phone book**”.

The system will ask “**Delete copy of phonebook from the system?**” To confirm, pronounce “**Yes**”.

Download the phonebook

If you chose not to download the phonebook during the phone pairing procedure, or if you recently deleted the current phonebook, the **USER DATA** item will be available in the **PHONEBOOK** menu.



To download a paired mobile phone phonebook using manual interaction, proceed as follows:

Select **PHONEBOOK**, and then press **OK** or ↵.



Or, using voice interaction

Press , pronounce “**Settings**”, wait shortly for feedback and then pronounce “**Download phone book**”.

Add contacts

If your mobile phone does not support automatic downloading during phone pairing, the **USER DATA** item will be available in the **ADD CONTACTS** menu.



To copy contacts from your mobile phone to the hands-free phone system using manual interaction, proceed as follows:

Select **ADD CONTACTS** and then press **OK** or ↵.



Or, using voice interaction:

Press , pronounce “**Settings**”, wait shortly for feedback and then pronounce “**Add Contacts**”.

Then follow the instructions given on your mobile phone owner’s manual for transferring contacts.

Reset user data



To reset all user data and phonebooks/contacts for paired phones to the default values using manual interaction, proceed as follows:

Select **DELETE ALL** and then press **OK** or ↵.

The system will display the question **Delete all?**. To confirm, press **OK** or ↵.



Or, using voice interaction:

Press , pronounce “**Settings**”, wait shortly for feedback and then pronounce “**Reset all**”.

The system will ask “**Delete all data saved by users from the system?**”. To confirm, pronounce “**Yes**”.

MEDIA PLAYER SETTINGS

Autoplay

When the **Autoplay option** is on, **Blue&Me™** will start to play the audio files on your USB device as soon as you turn the ignition key **MAR**. Once you activate this option, the first time you use the player, playback will start automatically.

The **Autoplay option** shall be disabled (when required) before connecting your USB device to the USB port and building or updating the media library.



To change **Autoplay setting** using manual interaction, proceed as follows:

Open the Main Menu, select **SETTINGS, MEDIA PLAYER, AUTOPLAY** and then press **OK** or ↵.

To activate Autoplay, select **AUTOPLAY ON** and press **OK** or ↵. To deactivate Autoplay select **AUTOPLAY OFF** and press **OK** or ↵.



Or, using voice interaction:

Press  and pronounce “**Autoplay on**” or “**Autoplay off**”.

Note

If you change the **Autoplay settings** after connecting the USB device, new setting will be activated the next time you connect a different USB device (or the same USB device with updated track library).

Shuffle

Use the **Shuffle** option to change the playback sequence. With **Shuffle** option on, **Blue&Me™** will play digital audio files at random.



To change **Shuffle** setting using manual interaction, proceed as follows:

Open the Main Menu, select **SETTINGS, MEDIA PLAYER, SHUFFLE** and then press **OK** or ↵.

To activate the **Shuffle** option, select **SHUFFLE ON** and press **OK** or ↵. To deactivate it, select **SHUFFLE OFF** and press **OK** or ↵.



Or, using voice interaction:

Press  and pronounce “**Shuffle on**” or “**Shuffle off**”.

Loop

Use the **Loop** option to repeat a track.



To activate the Loop option using manual interaction, proceed as follows:

Open the Main Menu, select **SETTINGS, MEDIA PLAYER, LOOP** and then press **SRC/ OK** or ↵.

To activate the **Loop** option, select **LOOP ON** and press **OK** or ↵. To deactivate it, select **LOOP OFF** and press **OK** or ↵.



Or, using voice interaction:

Press **⊞** and pronounce “**Loop on**” or “**Loop off**”.

Note

With **Loop** option on, previous and next track playback will pass to the previous or next audio track, that will start to be repeated.

ADVANCED OPTIONS



To navigate to the **ADV. OPTIONS**, menu using manual interaction, proceed as follows:

Press ↵ to open the Main Menu then select **SETTINGS** by pressing **OK** or ↵.

Select **ADV. OPTIONS** and then press **OK** or ↵.



Or, using voice interaction:

Press **⊞**, pronounce “**Settings**” and then “**Advanced Options**”.

Within the **ADV. OPTIONS** menu you can access the **SYS CODE**.

Note

This code is an 8-digit number (device ID) which uniquely identifies the **Blue&Me™** system installed on your car and cannot be changed.

Accessing the device ID

For certain operations, it might be necessary to know the **Blue&Me™** system code.



To access the system code by manual interaction, proceed as follows:

Select **SYS CODE** and then press **OK** or ↵.

The instrument panel display will show your **Blue&Me™** system code.

Press **OK** or ↵ or **ESC** to quit.



Or, using voice interaction:

Press **⊞**, pronounce “**Settings**”, wait shortly for feedback and then pronounce “**Device ID**”.

The instrument panel display will show your **Blue&Me™** system code.

Press **OK** or ↵ or **ESC** to quit.

Changing the GPRS code

If your mobile phone carrier requires to change the GPRS code, you can perform this operation via the **ADV. OPTIONS** menu.

 To change the GPRS code using manual interaction, proceed as follows:

Go to the **GPRS CODE** menu and press **OK** or ↵.

The display will show **GPRS:**, and a list of digits (1, 2, 3, 4, 5, 6, 7, 8, 9), **DEFAULT**, and **DISABLE**. To select the new GPRS code, press ↑ and ↓ until choosing the required option, then press **OK** or ↵. To store the default value, select **DEFAULT**. To disable the connection code, select **DISABLE**.

After setting the new GPRS code, **Blue&Me™** will display the message **GPRS CODE SET**.

 To set the GPRS code using voice interaction, proceed as follows:

Press , pronounce **“Settings”** and then **“Connection code”**.

Blue&Me™ will prompt “The current GPRS connection code is *value*. To change code say a number from 1 to 9 or say **“Default”**. To disable the connection code say **“Disable”**. To change the code, say a number from 1 to 9 or say **“Default”**. To disable the connection code say **“Disable”**. (In previous text, *value* is the GPRS connection code set at that moment).

After setting the new connection code, **Blue&Me™** will say “The Connection Code is set to *value*” (here *value* corresponds to the new GPRS code set).



EXIT THE SETTINGS MENU

At the end of any of the operations described above, you can exit the settings menu as described below.

 To exit the **SETTINGS** menu using manual interaction:

Select **EXIT** and then press **OK** or ↵.

Or, using voice interaction:

 Press , and pronounce **“Exit”**.

Blue&Me™ SUPPORTED MOBILE PHONES

Blue&Me™ supports your personal devices via the **Bluetooth®** wireless technology and USB.

To get updated information about the devices supported by **Blue&Me™**, contact Fiat Dealership or consult the dedicated site at www.fiat.com.

MOBILE PHONES WITH Bluetooth® WIRELESS TECHNOLOGY

Blue&Me™ supports most of the mobile phones supporting **Bluetooth®** 1.1 and HandsFree 1.5 profile (refer to **Bluetooth®** wireless connection specifications given on your mobile phone owner's manual).

Due to the different marketed software versions for mobile phones, certain auxiliary functions (e.g.: answering a second incoming phone call, transferring phone call from hands-free phone system to mobile phone and vice versa, etc.) could not exactly correspond to what described in this manual. In any case, phone conversation using the hands-free phone kit is not impaired.

“Pull” phones (phonebook automatically downloaded)

“Pull” phone means that your mobile phone supports phonebook automatic download with **Bluetooth®** wireless technology, your whole phonebook will be automatically downloaded to **Blue&Me™** during phone pairing procedure.

To consult the list of mobile phones and functions supported, consult the dedicated website www.fiat.com **Blue&Me™** or Customer Services on 00800.3428.0000.

You will also find:

- a quick guide with advice on usage;
- a guide for using your mobile phone for recording;
- advice on connection to an iPod;
- files in the 9 voice recognition languages available that can be downloaded onto **Blue&Me™** Nav (Italian, French, English, German, Spanish, Portuguese, Dutch, Polish, Brazilian Portuguese).

“Push” phones (phonebook not automatically downloaded)

“Push” phone means that your mobile phone supports the single contact download with **Bluetooth®** wireless technology. During the pairing procedure you will be required to send phonebook contacts from your mobile phone (your phonebook is not automatically downloaded during the phone pairing procedure).

Mobile phones with message reader (not all mobile phones support listening to incoming SMS messages)

If your mobile phone can send messages through the **Bluetooth®** wireless technology, it is possible to read incoming messages through the **Blue&Me™** hands-free kit, to store them in the dedicated inbox or to delete them.

SUPPORTED USB MEMORY DEVICES

USB MEMORY DEVICES

The multimedia player is compatible with most of the USB mass storage devices 1.0, 1.1 or 2.0, which can be configured as hard disks.

MANAGEMENT OF AUDIO FILES FROM iPod DEVICES

To improve the connection of your iPod with **Blue&Me™**, it is usually necessary to carry out these few simple operations on your iPod :

- configure the iPod for use as an external disc, referring to the iPod instruction manual;
- if the configuration has been made on an Apple PC, make the configuration in Windows format:
- store the sound tracks as audio files compatible with **Blue&Me™**.

These operations do not compromise listening quality or the accessibility of tracks managed by the iPod.

What I can do

- Listen to tracks with digital quality
- Select tracks (by Artist, Album, Genre etc.) by voice control or using the controls on the steering wheel
- Display information about the track being played (song title, artist, etc.) on the instrument panel.
- Recharge the iPod via USB connection.

What I cannot do

- Playing of audio tracks from iPod devices not configurable as external disks or iPhone (without Media Player **Blue&Me™** adapter, see following Note).

Note

A Media Player **Blue&Me™** adapter is available in Lineaccessori Fiat, to play the music tracks in iPod or iPhone models that cannot be configured as an external disk.

Note

It is advisable not to use USB devices equipped with the “password” function. If the USB device is equipped with this function, always ensure that the function is disabled.

The media player supports just one media library. When connecting a new USB device, **Blue&Me™** will build a new library replacing the existing one.

Supported digital audio files

The media player supports audio files with the following formats:

Extension	Audio coding
.wma	It supports standards WMA release 1 and WMA release 2. (WMA2 = 353, WMA1 = 352). It supports audio formats WMA Voice.
.mp3	file MPEG-1 Layer 3 (sampling frequencies: 32 kHz, 44.1 kHz and 48 kHz) and MPEG-2 layer 3 (16 kHz, 22.05 kHz e 24 kHz). The following bit rates are supported: 16 kbps, 32 kbps, 64 kbps, 96 kbps, 128 kbps, and 192 kbps. It also supports Fraunhofer extension MP2.5 (sampling frequencies: 8 kHz, 11.025 kHz and 12 kHz).
.wav	digital audio file, without data compression.
.aac .M4A MP4	file MPEG-4 (sampling frequencies: 22,05 kHz ÷ 48 kHz) The following bit rates are supported: 8Kbps ÷ 529 kbps

Note

The media player does not support audio files compressed with other formats and DRM (Digital Right Management) protected audio files. Non-supported audio files that may be present on the USB device will be ignored.

Supported playlist formats

The media player supports the following playlist formats:

- ❑ .m3u – file containing a list of tracks. (release 1 and 2)
- ❑ .wpl – Windows®-based file containing a playlist. (playlist capacity limit for this format is 300Kb). Playlists with extension .wpl can be built with Microsoft® Windows Media® Player.

The media player does not support nested or linked playlists. Playlist tracks relative and absolute paths are supported.

The media player does not support playlists built by application software based on specific criteria.

The media player will play playlists with paths leading to digital audio files in folders.

For further details on how to build playlists for **Blue&Me™**, refer to section PRACTICAL HINTS FOR USING THE MEDIA PLAYER.

Trade-marks

Microsoft® and Windows® are Microsoft Corporation registered trade-marks.

Sony® is a Sony Corporation registered trade-mark.

Ericsson® is a Telefonaktiebolaget LM Ericsson registered trade-mark.

Motorola® is a Motorola, Inc. registered trade-mark.

Nokia® is a Nokia Corporation registered trade-mark.

Siemens® is a Siemens AG registered trade-mark.

Orange™ is an Orange Personal Communications Services Limited registered trade-mark.

Audiovox® is an Audiovox Corporation registered trade-mark.

Bluetooth® is a Bluetooth® SIG, Inc registered trade-mark.

Lexar™ and JumpDrive® are Lexar Media, Inc. registered trade-marks.

SanDisk® and Cruzer™ are SanDisk Corporation registered trade-marks.

iPod, iTunes, iPhone are Apple Inc. registered trade-marks.

The other trade-marks are proprietary of the respective Companies.

VOICE COMMANDS (KEYWORDS) - SUMMARY

The following tables list the voice commands available on **Blue&Me™**. For each voice command is shown the “Keyword” (i.e.: the main voice command) and synonyms that may be used.

ALWAYS AVAILABLE VOICE COMMANDS

- Help
- Menu

*Activates the “**Help/Menu**” function, that gives a list of voice commands available for the current context*

- Cancel

Cancels voice interactions and deactivates the voice recognition system

- Repeat

Repeats the last spoken utterance

HANDS-FREE KIT VOICE COMMANDS

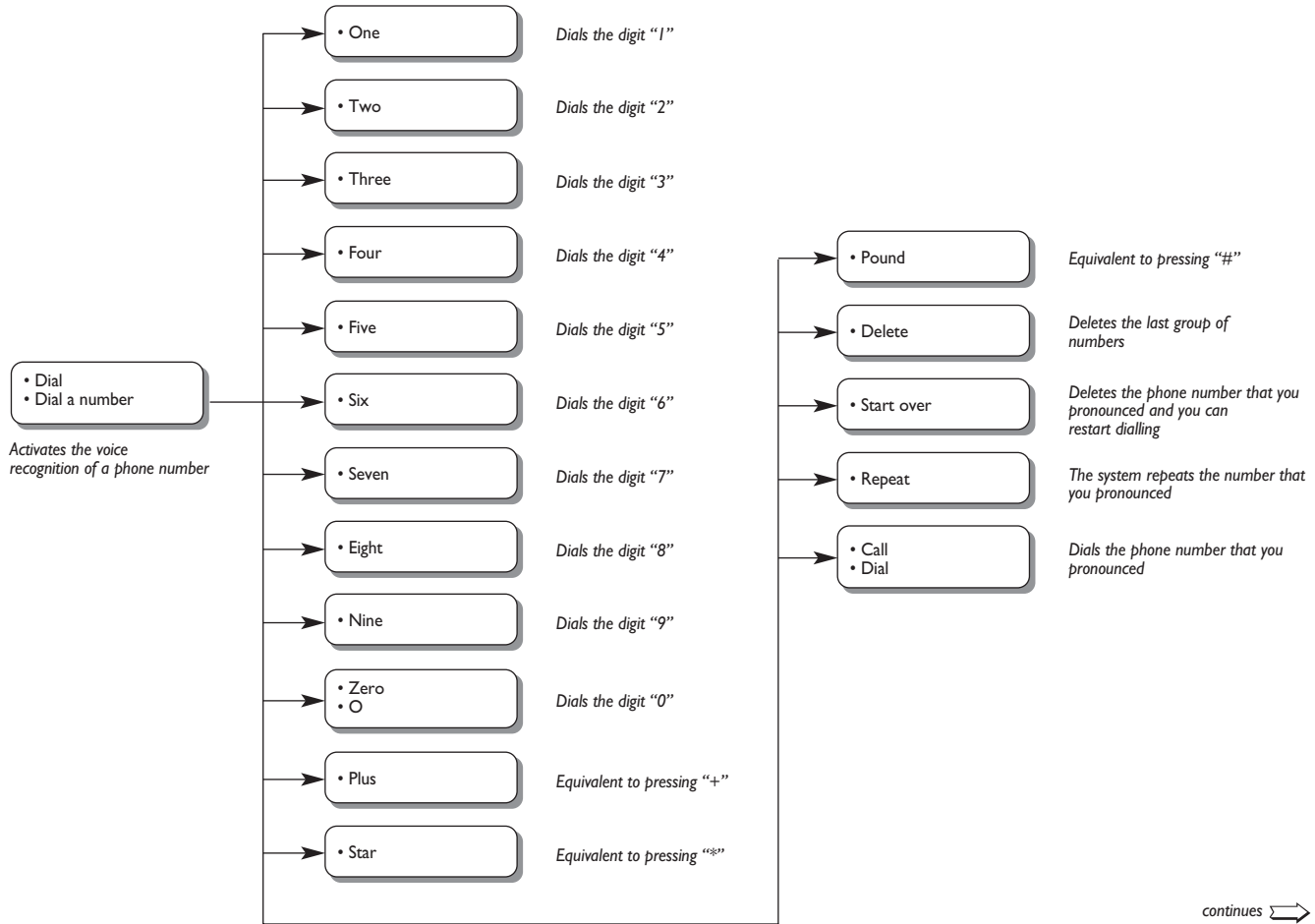

⇒ continued

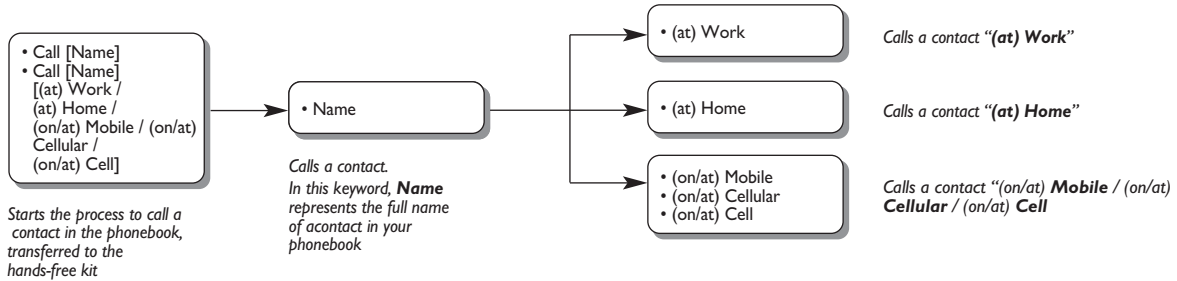

- Telephone
• Phone

Activates the phone function and speaks helpful information for using the hands-free phone

- Callback

Dials the phone number of the last caller

- Redial

Dials the phone number of the last person called

MESSAGE READER VOICE COMMANDS (KEYWORDS)

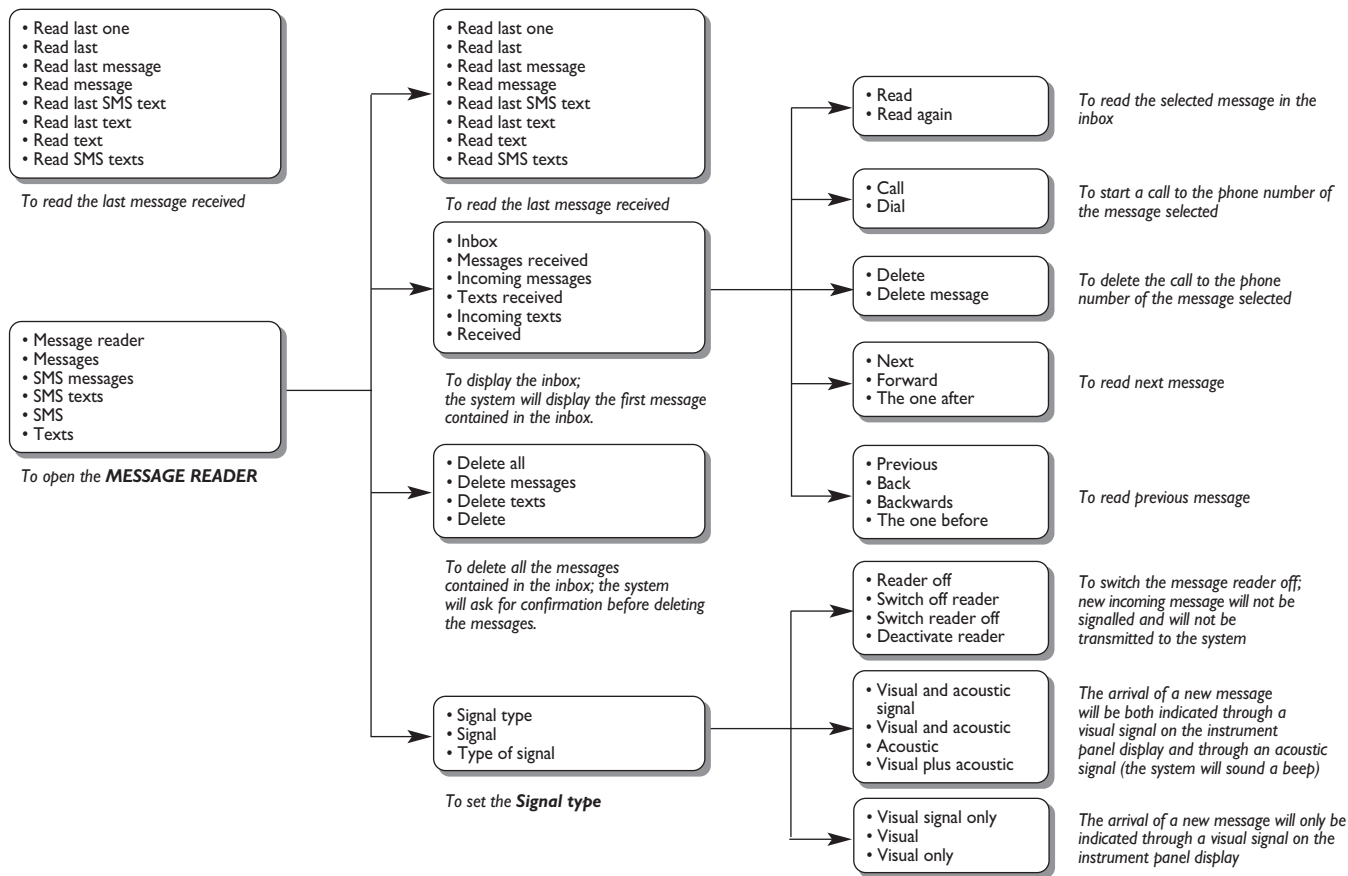

MEDIA PLAYER VOICE COMMANDS

- Media player
- Media
- Music

*Enters the **MEDIA PLAYER** menu*

- Play
- Play music
- Play media

Activates playback

- Stop
- Stop music
- Stop media

Stops playback

- Next
- Next track
- Next song
- The one after

Plays next track

- Previous
- Previous track
- Previous song
- The one before

Plays previous track

- Shuffle on
- Random order on

Activates random track playing

- Shuffle off
- Random order off

Deactivates random track playing

- Loop on
- Loop track on
- Cycle on

Activates track repeat

continues 

⇒ *continued*

- Loop off
- Loop track off
- Cycle off

Deactivates track repeat

- Now playing
- What's playing
- What is playing
- What's this track

Displays current track data

- Folders
- Folder
- Browse folders

*Enters media player **FOLDERS** menu*

- Artists
- Artist
- Browse artists

*Enters media player **ARTISTS** menu*

- Genres
- Genre
- Browse genres
- Type of music
- Styles
- Music styles
- Types
- Music types

*Enters media player **GENRES** menu*

- Albums
- Album
- Browse albums

*Enters media player **ALBUMS** menu*

- Playlists
- Playlist
- Browse playlists

*Enters media player **PLAYLISTS** menu*

⇒ continued

- Autoplay on
- Autoplay media on
- Autoplay music on

Activates automatic playback when connecting the USB device to the relevant port in the car

- Autoplay off
- Autoplay media off
- Autoplay music off

Deactivates automatic playback when connecting the USB device to the relevant port in the car

- Play anything
- Play something

Activates playback of all digital audio tracks

- Media settings

*Enters **MEDIA PLAYER** menu*

SETTINGS FUNCTION VOICE COMMANDS

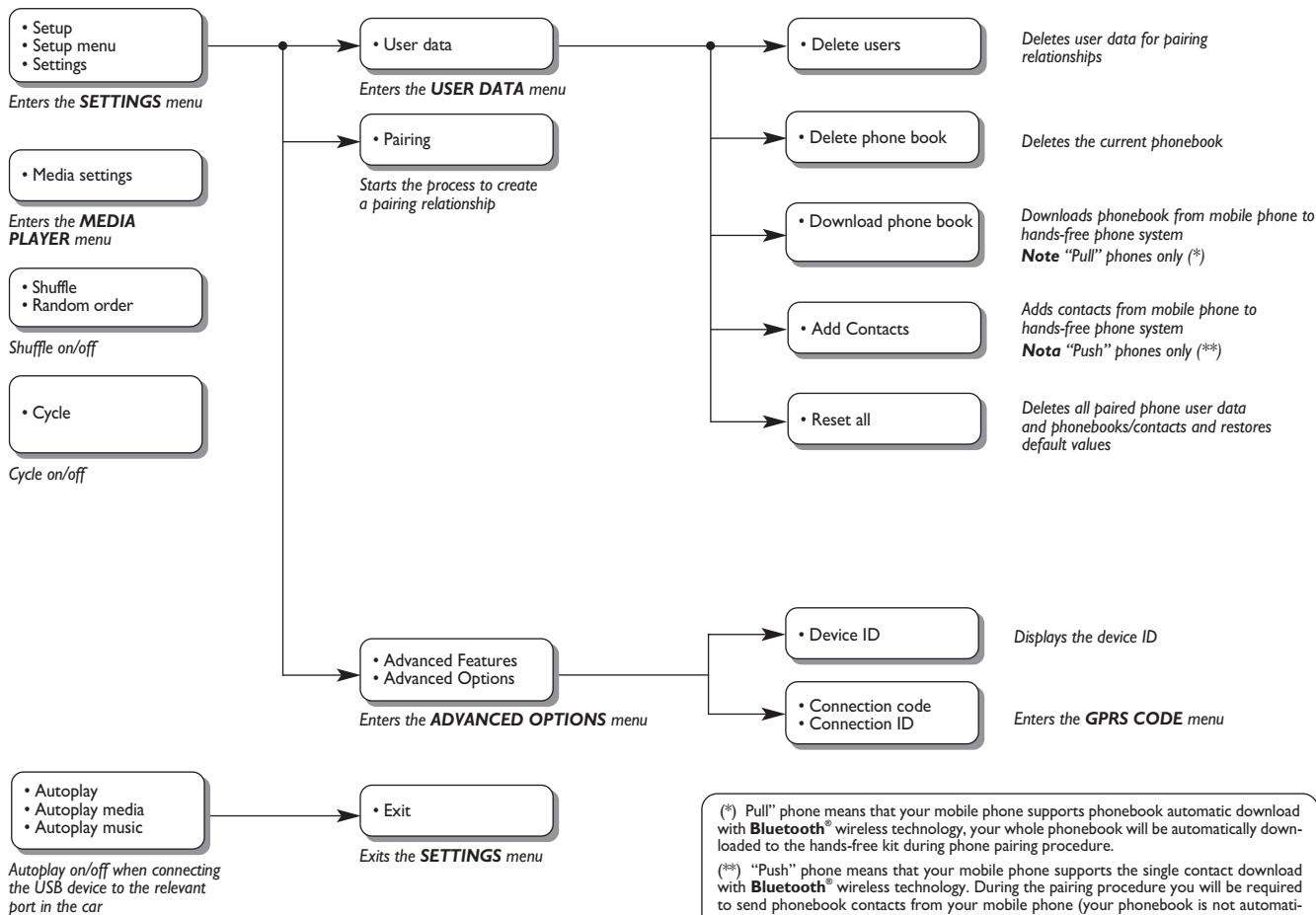

(*) "Pull" phone means that your mobile phone supports phonebook automatic download with **Bluetooth**® wireless technology, your whole phonebook will be automatically downloaded to the hands-free kit during phone pairing procedure.

(**) "Push" phone means that your mobile phone supports the single contact download with **Bluetooth**® wireless technology. During the pairing procedure you will be required to send phonebook contacts from your mobile phone (your phonebook is not automatically downloaded during the phone pairing procedure).

TROUBLESHOOTING

HANDS-FREE KIT









General - display screen

Problem	Probable Cause	Possible Solution
<p>Display screen shows: NO PHONEBOOK</p> <p>Or the system says: “As requested, the phonebook has not been copied. To copy the phonebook onto the system go to SETTINGS menu and select “USER DATA”. To dial a phone number, say “Dial”.”</p>	<p>For “pull” phones</p> <ul style="list-style-type: none"> <input type="checkbox"/> When the system asked “The data from the phonebook will now be copied onto the system. Continue?”, you responded with “No” <input type="checkbox"/> You have not downloaded your phonebook via the SETTINGS menu <input type="checkbox"/> The downloaded phonebook was deleted <p>For “push” phones</p> <ul style="list-style-type: none"> <input type="checkbox"/> When the system asked “The data from the phonebook will now be copied onto the system. Continue?”, you responded with “No”. <input type="checkbox"/> You have not sent contacts to the system using the ADD CONTACTS procedure <input type="checkbox"/> The downloaded phonebook was deleted 	<p>For “pull” phones</p> <ul style="list-style-type: none"> <input type="checkbox"/> Use the option PHONEBOOK in the SETTINGS menu to download the phonebook again <input type="checkbox"/> Enter contact information in the phonebook on your mobile phone and then download the phonebook again ➔ SETTING FUNCTIONS - MANAGING USER DATA AND PHONEBOOK <p>For “push” phones</p> <ul style="list-style-type: none"> <input type="checkbox"/> Use the option ADD CONTACTS in the SETTINGS menu to send contacts in the phonebook on your mobile phone to the system ➔ SETTING FUNCTIONS - MANAGING USER DATA AND PHONEBOOK

Problem	Probable Cause	Possible Solution
<p>Display screen shows: PH/BOOK EMPTY</p> <p>Or the system says “Phonebook empty. To add contacts to the phonebook, go to the SETTINGS menu and select “USER DATA”. To dial a phone number, say “DIAL.”</p>	<p>For “pull” phones</p> <ul style="list-style-type: none"> <input type="checkbox"/> You answered “Yes” to “The data from the phonebook will now be copied onto the system. Continue?” but the downloaded phonebook does not include any valid contacts <input type="checkbox"/> You have used the option PHONEBOOK in the SETTINGS menu, but the mobile phone phonebook does not include any valid contacts <p>For “push” phones</p> <ul style="list-style-type: none"> <input type="checkbox"/> When the system asked “The data from the phonebook will now be copied onto the system. Continue?”, you answered “Yes” but did not send any valid contacts during the ADD CONTACTS procedure <input type="checkbox"/> You used the ADD CONTACTS option but did not send any valid contacts to the system 	<p>For “pull” phones</p> <ul style="list-style-type: none"> <input type="checkbox"/> Enter valid contact information (name and one phone number at least) in the phonebook on your mobile phone, then download the phonebook again ➔ SETTING FUNCTIONS - MANAGING USER DATA AND PHONEBOOK <p>For “push” phones</p> <ul style="list-style-type: none"> <input type="checkbox"/> Download the phonebook again and make sure to send valid contacts to the system, using your mobile phone, when prompted <input type="checkbox"/> Use the option ADD CONTACTS in the SETTINGS menu to send contacts from your mobile phone to the system ➔ SETTING FUNCTIONS - MANAGING USER DATA AND PHONEBOOK

Problem	Probable Cause	Possible Solution
<p>Display screen shows: NO PHONE</p> <p>Or the system says “There’s no bluetooth phone connected”</p>	<ul style="list-style-type: none"> <input type="checkbox"/> The paired mobile phone is turned off <input type="checkbox"/> The paired mobile phone is not within range of the system (the mobile phone should be located within approximately 10 m of the system) <input type="checkbox"/> Bluetooth® wireless technology connection has been disabled on your mobile phone (“Blue&Me” ID) 	<ul style="list-style-type: none"> <input type="checkbox"/> Turn the paired mobile phone on <input type="checkbox"/> Make sure that your phone is paired <input type="checkbox"/> Make sure that the Bluetooth® wireless technology connection on your mobile phone is enabled (“Blue&Me” ID) <input type="checkbox"/> Make sure that the mobile phone you paired with the system is within range
<p>Display screen shows: TEL DISCONN.</p>	<ul style="list-style-type: none"> <input type="checkbox"/> A technical error occurred with the mobile phone Bluetooth® wireless technology capabilities <input type="checkbox"/> During an ongoing phone conversation, the mobile phone was taken out of the system range 	<ul style="list-style-type: none"> <input type="checkbox"/> Reset Blue&Me™ by turning the mobile phone off and on <input type="checkbox"/> Reset Blue&Me™ by turning the ignition key to STOP and then to MAR again
<p>Display screen shows: PAIR. FAILED</p> <p>Or the system says “Pairing failed. Please try again”</p>	<ul style="list-style-type: none"> <input type="checkbox"/> A technical error occurred during the pairing procedure 	<ul style="list-style-type: none"> <input type="checkbox"/> Verify the correct PIN number, and try entering it again <input type="checkbox"/> Reset the mobile phone by turning it off and on, and then retry the pairing procedure ➔ SETTING FUNCTIONS - PAIRING YOUR MOBILE PHONE

Problem	Probable Cause	Possible Solution
<p>Display screen shows: PAIR. FAILED</p> <p>Or the system says “Bluetooth pairing timed out. Please try again later.”</p>	<p>After three minutes, each attempt to enter the PIN number fails since pairing timed out</p>	<p>Retry the pairing procedure. During the PIN entering step, verify that the PIN number you are entering on the mobile phone is the same number that is shown on the instrument panel display</p> <p>➔ SETTING FUNCTIONS - PAIRING YOUR MOBILE PHONE</p>
<p>Display screen shows: PRIVATE NUMBER</p>	<ul style="list-style-type: none"> <input type="checkbox"/> The caller is not recognized as a name stored in the phonebook, and the paired mobile phone does not have a called ID feature <input type="checkbox"/> The caller has blocked caller ID to prevent the system from displaying the caller’s name and/or phone number 	<p>Enter a contact in your mobile phonebook for the incoming call, and then download your phonebook/contact again</p> <p>In this case, nothing can be done and the message will always appear</p>
<p>Display screen shows: ONLY AT REST</p> <p>Or the system says: “This function is only available when the vehicle is stationary”</p>	<p>Even occasional short viewings of the car display may be hazardous if your attention has been diverted away from your driving tasks. Certain Blue&Me™ functions, which require the user to give attention to the car display, are only available when the car is stopped</p>	<p>Stop your car and attempt to perform the function again manually, or continue driving and perform the function using the voice recognition system</p>

Problem	Probable Cause	Possible Solution
<p>The system did not respond to voice command or key press</p>	<ul style="list-style-type: none"> <li data-bbox="619 109 1029 188">❑ If you do not speak soon enough after pressing , the system will interrupt voice interaction <li data-bbox="619 210 1029 339">❑ If you are speaking too far from the in-car microphone (for example, if you are sitting in the back seat), the system may not hear your voice command <li data-bbox="619 361 1029 468">❑ If you don't wait for the tone after pressing , the system will get only a portion of the keyword and will misrecognize it <li data-bbox="619 512 1029 641">❑ If you don't press  before pronouncing a voice command, the system will not activate voice recognition and therefore recognize your voice commands <li data-bbox="619 664 1029 770">❑ If you don't press  to enter the Main Menu, it will not be possible to access manually the Blue&Me™ menu <li data-bbox="619 792 1029 899">❑ If after pressing , you don't take action within approx. eight seconds, the system will not respond to your key press 	<ul style="list-style-type: none"> <li data-bbox="1066 109 1476 165">❑ Press  and pronounce the voice command again <p data-bbox="1090 182 1476 238">Make sure that you face forward and speak clearly at a normal volume</p> <ul style="list-style-type: none"> <li data-bbox="1066 664 1485 770">❑ Press  and try the operation again. Make sure to take action within approximately eight seconds after pressing 

Problem	Probable Cause	Possible Solution
The system prompted to enter a PIN number, but no phone pairing procedure was running	After you delete the pairing-related user information on your mobile phone, the Bluetooth [®] pairing relationship between your mobile phone and Blue&Me [™] will no longer work	Select option DELETE USERS on the system and delete all pairings; then, pair the phone again <ul style="list-style-type: none"> ➤ SETTING FUNCTIONS - MANAGING USER DATA AND PHONEBOOK ➤ SETTING FUNCTIONS - PAIRING YOUR MOBILE PHONE
When in close proximity of the car, answering a phone call directly using the mobile phone “answer” button, will automatically activate the free-hands phone function (the caller’s voice is played through the car speakers)	Some types of mobile phones require you to set the phone to choose between automatic incoming call transfer to the system or non-automatic incoming call transfer (you will transfer the call using the mobile phone keypad, as required)	Refer to your mobile phone owner’s manual to find out how to set up the default location for phone audio when a phone call is received

Problem	Probable Cause	Possible Solution
<p>Pairing a paired mobile phone, the display screen shows: Pair. failed</p> <p>Or the system says “Pairing failed. Please try again”</p>	<p>Before re-pairing with a mobile phone, information for the first pairing on Blue&Me™ must be deleted</p>	<p>Remember that the pairing procedure will only need to be performed once for your mobile phone. After this procedure, Blue&Me™ will automatically connect to your phone each time you get into the car and turn the ignition key to MAR.</p> <p>To pair the phone again, select DELETE USERS and then re-pair the phone</p> <ul style="list-style-type: none"> ➤ SETTING FUNCTIONS - MANAGING USER DATA AND PHONEBOOK ➤ SETTING FUNCTIONS - PAIRING YOUR MOBILE PHONE
<p>After downloading the phonebook from the mobile phone contacts' middle names/initials, prefixes or suffixes are not recognized by the voice recognition system</p>	<p>The system does not support the use of prefixes, suffixes, or middle names/initials when calling contacts by voice</p>	<p>When calling contacts by voice, pronounce the contact's name without using prefixes, suffixes or, middle names/initials.</p> <p>If you have two entries with similar first and/or last name in your phonebook, modify one of the entries in the mobile phone to make it unique.</p> <p>Then, re-download the phonebook to the hands-free phone system</p>

Problem	Probable Cause	Possible Solution
Phone numbers containing international dialling codes (e.g.: +39 Italy, +44 UK, +33 France, etc.) are difficult to call	On certain mobile phones, when downloading names and/phone numbers to the hands-free system, the sign “+” is omitted	Replace “+” with “00” (e.g.: +39 becomes 0039).

To consult the list of mobile phones and functions supported, consult the dedicated website www.fiat.com **Blue&Me™** or Customer Services on 00800.3428.0000.

You will also find:

- a quick guide with advice on usage;
- a guide for using your mobile phone for recording;
- advice on connection to an iPod;
- files in the 9 voice recognition languages available that can be downloaded onto **Blue&Me™** Nav (Italian, French, English, German, Spanish, Portuguese, Dutch, Polish, Brazilian Portuguese).

MESSAGE READER

Problem	Probable Cause	Possible Solution
<p>I receive SMS messages on the cellular telephone but not on Blue&Me™</p>	<p>Not all cellular telephones support SMS messages transfer to Blue&Me™</p>	<p>Check that your cellular telephone supports the function for transmitting SMS Messages by Bluetooth technology or, for further information, see chapter “LIST OF TELEPHONE SETS SUPPORTED BY Blue&Me™”, or site www.fiat.com</p>
<p>SMS texts received from your phone carrier service center show abnormal displaying of sender's name or number</p>	<p>Not all mobile phones support correct transfer of the phone carrier's name sending the SMS text to Blue&Me™</p>	<p>–</p>
<p>Blue&Me™ stopped receiving messages from your cellular telephone</p>	<p>You might have set by mistake the option NOT ACTIVE from menu Notification settings</p>	<p>Set, on menu notification settings, either VISUAL+ACOUSTIC notification or NOT VISUAL notification</p> <p>➤ READER FUNCTIONS SMS MESSAGES, paragraph NOTIFICATION SETTINGS</p>
<p>You cannot display some SMS messages, present on your cellular telephone, on Blue&Me™ SMS message list</p>	<p>Blue&Me™ is capable to read and store last 20 received SMS messages while the telephone set is connected to the system. Messages received in other contexts are not transferred to Blue&Me™</p>	<p>SMS messages stored by Blue&Me™ can be deleted</p> <p>➤ READER FUNCTIONS SMS MESSAGES, paragraphs SMS MESSAGES MANAGEMENT AND DELETING ALL SMS MESSAGES</p>

Problem	Probable Cause	Possible Solution
Some SMS messages or part of them are not read, or are not correctly read by Blue&Me™ hands-free kit	Some “special” characters within received SMS message, cannot be interpreted by Blue&Me™	–
Blue&Me™ SMS messages reader displays sender telephone number instead of sender name	Probably, during portable phone registration step, you chose not to download the telephone book, or, if your portable phone only supports the management of single contacts, you chose to download some contacts only	To download your cellular telephone book, refer to special item on menu Settings ➔ SETTING FUNCTIONS, paragraphs CELLULAR TELEPHONE REGISTRATION and USER DATA MANAGEMENT
Sometimes received SMS message sender cannot be called	Some SMS messages, e.g. the ones sent by telephone operator, have no associated sender telephone number, so option CALL cannot be used	–

MEDIA PLAYER

Problem	Probable Cause	Possible Solution
<p>Displayed message: NO MEDIA</p> <p>Or Blue&Me™ says: “No media found”</p>	<ul style="list-style-type: none"> <input type="checkbox"/> No USB device connected to the USB port in the car. <input type="checkbox"/> No digital audio file stored on the USB memory device. <input type="checkbox"/> If power supply is interrupted, (e.g.: car battery disconnection), Blue&Me™ will loose power temporarily. In this event media library shall be rebuilt <input type="checkbox"/> Your USB memory device is not supported by Blue&Me™. 	<ul style="list-style-type: none"> <input type="checkbox"/> Follow the instructions to connect your USB device to Blue&Me™. <input type="checkbox"/> Store digital audio files on your USB memory devices following the instructions given by your media file software. <input type="checkbox"/> Remove the USB device from the USB port and refit it to build again the media library. <input type="checkbox"/> Check whether your USB device is supported by Blue&Me™.
<p>After connecting your USB device and turnin the ignition key to MAR, no music is played</p>	<p>Building the media library may require a few minutes.</p>	<p>Wait for library building. If the time required to build the library is excessive, you can intervene by reducing the number of audio files stored on your USB device.</p>
<p>After inserting a USB device and turning the car key to the MAR position, Blue&Me™ malfunctions occur. (e.g. failure to reproduce musical tracks or no voice messages)</p>	<p>You may have used a USB device with the PASSWORD function enabled.</p>	<p>Disable on the USB device such function.</p>

Problem	Probable Cause	Possible Solution
Displayed message: NO PLAYLISTS Or Blue&Me™ says: “No playlist found”	No playlist is stored on the USB device connected	Build a playlist on your computer using your media file software and then copy it to your USB device
Displayed message: INVALID	Playlist is damaged or invalid	<ul style="list-style-type: none"> <input type="checkbox"/> Make sure the playlist is in <i>.m3u</i> or <i>.wpl</i> format. <input type="checkbox"/> Build the playlist again following the instructions given in section BUILDING PLAYLISTS FOR Blue&Me™ - PRACTICAL HINTS. <input type="checkbox"/> If the problem persists, delete the playlist from your USB device.
Displayed message: EMPTY PLAYLIST Or Blue&Me™ says: “Empty playlist.”	<ul style="list-style-type: none"> <input type="checkbox"/> No media file is contained in the playlist <input type="checkbox"/> The <i>.wpl</i> file is too large for Blue&Me™ memory capacity <input type="checkbox"/> The playlist does not contain references to media files on your USB device 	<ul style="list-style-type: none"> <input type="checkbox"/> Delete the playlist from your USB device or copy media files to the playlist using your media file software. <input type="checkbox"/> Reduce the number of tracks in the playlist, using your media file software.
Displayed message: BAD MEDIA	Digital audio file is damaged or invalid	Delete bad media from your USB device
Indication on sound system display: MEDIAPLAYER in absence of USB device connected to the car USB port	The USB device has been removed from the car USB port with the ignition key at STOP	<ul style="list-style-type: none"> <input type="checkbox"/> To change the current audio source, press button OK or the dedicated buttons FM, AM, CD on the sound system front panel. <input type="checkbox"/> With ignition key at MAR, insert and then remove the USB device from the car USB port. <input type="checkbox"/> To avoid displaying of MEDIAPLAYER indication in absence of USB device, always remove the USB device when the ignition key is at MAR, or stop playback (with voice command STOP) before removing the USB device from the car USB port.

Problem	Probable Cause	Possible Solution
<p>Displayed message: PROTECTED Or Blue&Me™ says: “Protected content”.</p>	<p>The track selected is DRM-protected and it cannot be played by the media player</p>	<p>–</p>
<p>Blue&Me™ does not play all the digital audio files in the playlist</p>	<p>Your playlist contains DRM-protected files that cannot be played; or it contains references to invalid media files</p>	<p>For further details see section “SUPPORTED USB MEMORY DEVICES”</p>
<p>The media library does not show all the digital audio files stored on the USB device</p>	<ul style="list-style-type: none"> <input type="checkbox"/> Your playlist contains DRM-protected files that are ignored during playback <input type="checkbox"/> Your playlist contains more than 20.000 tracks, that is the max. number of files that can be copied to the media library. <input type="checkbox"/> The playlist stored on your USB device contains more than 20 nested folders. Nested folders files will not be copied to the media library. 	<p>–</p>
<p>After pronouncing a command, Blue&Me™ says: “Command not available”, although the command you prompt is a first level voice command</p>	<p>Certain commands are not available when the track is paused or the CD player is playing a track</p>	<p>If the track is paused, resume playback by pressing ESC. Then pronounce the voice command again.</p>

Problem	Probable Cause	Possible Solution
<p>The same USB memory device previously connected takes more than 10 seconds to restart playback on Blue&Me™</p>	<p>You removed the USB memory device from the PC before it was ready</p>	<p>To reset the USB memory device using Microsoft® Windows® XP, click on My Computer in the Start menu, click rightwards on the USB memory device, select Properties, select Tools, click on key “Check Now...” in field “Error-checking”, select “Automatically fix file system errors” and then click Start.</p> <p>To avoid future problems, remove the USB device using the option “Secure hardware removal”.</p>

iPod

Problem	Probable Cause	Possible Solution
iPod not working	<ul style="list-style-type: none"> <input type="checkbox"/> The iPod could have been updated with software that is not compatible with Windows Mobile™ (as Blue&Me™ is a system developed in partnership with Microsoft only systems that support Windows Mobile™ are compatible) <input type="checkbox"/> The iPod has not been configured as an external disk <input type="checkbox"/> It has been enabled for use as a external disc but there are tracks inside in M4P format (these formats are not supported by Blue&Me™) <input type="checkbox"/> iPod cannot be configured as an external disk (e.g. iPod Touch, etc.) 	<ul style="list-style-type: none"> <input type="checkbox"/> Use an alternative USB memory stick or reset the iPod for Windows <input type="checkbox"/> Enable usage as a external disc (this function cannot be selected with iPod touch and iPhones) <input type="checkbox"/> Modify the track format to one that is compatible with Blue&Me™ <input type="checkbox"/> Use the Lineaccessori Fiat Media Player Blue&Me™ adapter.
Playing of audio files from iPhone devices failed	<ul style="list-style-type: none"> <input type="checkbox"/> The iPhone devices are not configurable as external disks 	<ul style="list-style-type: none"> <input type="checkbox"/> Use the Media Player Blue&Me™ adapter, available from Lineaccessori Fiat

Problem	Probable Cause	Possible Solution
<p>With iPods or USB memory sticks the system continues playing the same track or the “forward” button has to be pressed to move on to the next track</p>	<p>The repetition function for each individual track may have inadvertently been activated</p>	<p>There is a specific item in the menu, like “continuous play” or “individual track repetition”, which must be deactivated.</p> <p>Proceed with the deactivation:</p> <ul style="list-style-type: none"> <input type="checkbox"/> press the controls activation button on the steering wheel <input type="checkbox"/> when requested by the system, say “DEACTIVATE CONTINUOUS PLAY” in a clear tone <input type="checkbox"/> wait for voice confirmation by the system which will say “CONTINUOUS PLAY DEACTIVATED”
<p>The iPod connected to the Blue&Me™ is not charged</p>	<p>When the ignition is ON the vehicle recharges the iPod unless the iPod is completely run down</p>	<p>Remember that your iPod must have some charge or wait a few minutes until the system recharges it</p>

PERSONAL DATA PROTECTION

Blue&Me™ functions entail personal data handling. In order to protect and to prevent non-authorized access to personal data, **Blue&Me™** has been implemented with the following criteria:

- ❑ Personal data connected to hands-free kit functions (phonebook and last calls) can only be accessed after automatic recognition of your **Bluetooth®** wireless technology enabled mobile phone;
- ❑ Stored personal data can be deleted using the specific **Blue&Me™** functions.
- ➡ For further details on how to delete personal data, refer to section **SETTINGS FUNCTION - MANAGING USER DATA**.

IMPORTANT Take into account that when leaving your car at a service centre, personal data stored on **Blue&Me™** (phonebook and last calls) may be disclosed or may be subject to improper use. Before leaving your car at the service centre you can delete stored data and phonebook from **Blue&Me™**.

- ➡ For further details on how to delete personal data and phonebook, refer to section **SETTINGS FUNCTION - MANAGING USER DATA**.

SYSTEM SOFTWARE USE NOTICE

This system contains software that is licensed to Manufacturer pursuant to a license agreement. Any removal, reproduction, reverse engineering or other unauthorized use of the software from this system in violation of the license agreement is strictly prohibited and may subject you to legal action.

WARNING Hacking the **Blue&Me™** device or installing unapproved software may lead to warranty void and compromises of safety and of the security of stored information.

END USER LICENSE AGREEMENT (“EULA”)

- You have acquired a device (“DEVICE”) which includes software licensed by Fiat Auto S.p.A. from one or more software licensors (“Fiat Auto S.p.A.’s Software Suppliers”). Such software products, as well as associated media, printed materials, and “on-line” or electronic documentation (“SOFTWARE”) are protected by international intellectual property laws and treaties. The SOFTWARE is licensed, not sold. All rights reserved.
- IF YOU DO NOT AGREE TO THIS END USER LICENSE AGREEMENT (“EULA”), DO NOT USE THE DEVICE OR COPY THE SOFTWARE. INSTEAD, PROMPTLY CONTACT FIAT AUTO S.p.A. FOR INSTRUCTIONS ON RETURN OF THE UNUSED DEVICE(S). **ANY USE OF THE SOFTWARE, INCLUDING BUT NOT LIMITED TO USE ON THE DEVICE, WILL CONSTITUTE YOUR AGREEMENT TO THIS EULA (OR RATIFICATION OF ANY PREVIOUS CONSENT).**

GRANT OF SOFTWARE LICENSE. This EULA grants you the following license:

- You may use the SOFTWARE as installed on the DEVICE.

DESCRIPTION OF OTHER RIGHTS AND LIMITATIONS

- **Speech Recognition.** If the SOFTWARE includes speech recognition component(s), you should understand that speech recognition is an inherently statistical process and that recognition errors are inherent in the process. Neither Fiat Auto S.p.A. nor its suppliers shall be liable for any damages arising out of errors in the speech recognition process.
- **Limitations on Reverse Engineering, Decompilation and Disassembly.** You may not reverse engineer, decompile, or disassemble the SOFTWARE, except and only to the extent that such activity is expressly permitted by applicable law notwithstanding this limitation.

- **Single EULA.** The end user documentation for the DEVICE may contain multiple versions of this EULA, such as multiple translations and/or multiple media versions (e.g., in the user documentation and in the software). Even if you receive multiple versions of the EULA, you are licensed to use only one (1) copy of the SOFTWARE.
- **No Rental.** Except as authorized by Fiat Auto S.p.A., you may not rent, lease, or lend the SOFTWARE.
- **SOFTWARE Transfer.** You may permanently transfer all of your rights under this EULA only as part of a sale or transfer of the DEVICE, provided you retain no copies, you transfer all of the SOFTWARE (including all component parts, the media and printed materials, any upgrades, this EULA and, if applicable, the Certificate(s) of Authenticity), and the recipient agrees to the terms of this EULA. If the SOFTWARE is an upgrade, any transfer must include all prior versions of the SOFTWARE.
- **Termination.** Without prejudice to any other rights, Fiat Auto S.p.A. or Fiat Auto S.p.A.'s Software Suppliers may terminate this EULA if you fail to comply with the terms and conditions of this EULA. In such event, you must destroy all copies of the SOFTWARE and all of its component parts.
- **Consent to Use of Data.** You agree that Fiat Auto S.p.A.'s Software Suppliers, their affiliates and/or their designated agent may collect and use technical information gathered in any manner as part of product support services related to the SOFTWARE. Fiat Auto S.p.A.'s Software Suppliers, their affiliates and/or their designated agent may use this information solely to improve their products or to provide customized services or technologies to you. Fiat Auto S.p.A.'s Software Suppliers, their affiliates and/or their designated agent may disclose this information to others, but not in a form that personally identifies you.
- **Internet-Based Services Components.** The SOFTWARE may contain components that enable and facilitate the use of certain Internet-based services. You acknowledge and agree that Fiat Auto S.p.A.'s Software Suppliers, their affiliates and/or their designated agent may automatically check the version of the SOFTWARE and/or its components that you are utilizing and may provide upgrades or supplements to the SOFTWARE that may be automatically downloaded to your DEVICE.

- **Additional Software/Services.** The SOFTWARE may permit Fiat Auto S.p.A., Fiat Auto S.p.A.’s Software Suppliers, their affiliates and/or their designated agent to provide or make available to you SOFTWARE updates, supplements, add-on components, or Internet-based services components of the SOFTWARE after the date you obtain your initial copy of the SOFTWARE (“Supplemental Components”).
 - If Fiat Auto S.p.A. provides or makes available to you Supplemental Components and no other EULA terms are provided along with the Supplemental Components, then the terms of this EULA shall apply.
 - If Fiat Auto S.p.A.’s Software Suppliers, their affiliates and/or their designated agent make available Supplemental Components, and no other EULA terms are provided, then the terms of this EULA shall apply, except that the Fiat Auto S.p.A.’s Software Suppliers or affiliate entity providing the Supplemental Component(s) shall be the licensor of the Supplemental Component(s).
 - Fiat Auto S.p.A., Fiat Auto S.p.A.’s Software Suppliers, their affiliates and/or their designated agent reserve the right to discontinue any Internet-based services provided to you or made available to you through the use of the SOFTWARE.
 - **Links to Third Party Sites.** The SOFTWARE may provide you with the ability to link to third party sites through the use of the SOFTWARE. The third party sites are not under the control of Fiat Auto S.p.A.’s Software Suppliers, their affiliates and/or their designated agent. Neither Fiat Auto S.p.A.’s Software Suppliers nor their affiliates nor their designated agent are responsible for (i) the contents of any third party sites, any links contained in third party sites, or any changes or updates to third party sites, or (ii) webcasting or any other form of transmission received from any third party sites. If the SOFTWARE provides links to third party sites, those links are provided to you only as a convenience, and the inclusion of any link does not imply an endorsement of the third party site by Fiat Auto S.p.A.’s Software Suppliers, their affiliates and/or their designated agent.

UPGRADES AND RECOVERY MEDIA

- If the SOFTWARE is provided by Fiat Auto S.p.A. separate from the DEVICE on media such as a ROM chip, CD ROM disk(s) or via web download or other means, and is labeled “For Upgrade Purposes Only” you may install one (1) copy of such SOFTWARE onto the DEVICE as a replacement copy for the existing SOFTWARE, and use it in accordance with this EULA, including any additional EULA terms accompanying the upgrade SOFTWARE.

INTELLECTUAL PROPERTY RIGHTS

All title and intellectual property rights in and to the SOFTWARE (including but not limited to any images, photographs, animations, video, audio, music, text and “applets,” incorporated into the SOFTWARE), the accompanying printed materials, and any copies of the SOFTWARE, are owned by Fiat Auto S.p.A.’s Software Suppliers, their affiliates or suppliers. The SOFTWARE is licensed, not sold. You may not copy the printed materials accompanying the SOFTWARE. All title and intellectual property rights in and to the content which may be accessed through use of the SOFTWARE is the property of the respective content owner and may be protected by applicable copyright or other intellectual property laws and treaties. This EULA grants you no rights to use such content. All rights not specifically granted under this EULA are reserved by Fiat Auto S.p.A.’s Software Suppliers, their affiliates and suppliers. Use of any on-line services which may be accessed through the SOFTWARE may be governed by the respective terms of use relating to such services. If this SOFTWARE contains documentation that is provided only in electronic form, you may print one copy of such electronic documentation.

EXPORT RESTRICTIONS

You acknowledge that the SOFTWARE is subject to U.S. and European Union export jurisdiction. You agree to comply with all applicable international and national laws that apply to the SOFTWARE, including the U.S. Export Administration Regulations, as well as end-user, end-use and destination restrictions issued by U.S. and other governments.

- **TRADEMARKS.** This EULA does not grant you any rights in connection with any trademarks or service marks of Fiat Auto S.p.A., Fiat Auto S.p.A.’s Software Suppliers, their affiliates or suppliers.
- **PRODUCT SUPPORT.** Product support for the SOFTWARE is not provided by Fiat Auto S.p.A.’s Software Suppliers, or their affiliates or subsidiaries. For product support, please refer to Fiat Auto S.p.A. support number provided in the documentation for the DEVICE. Should you have any questions concerning this EULA, or if you desire to contact Fiat Auto S.p.A. for any other reason, please refer to the address provided in the documentation for the DEVICE.
- **No Liability for Certain Damages.** EXCEPT AS PROHIBITED BY LAW, FIAT AUTO S.p.A.’S SOFTWARE SUPPLIERS AND THEIR AFFILIATES SHALL HAVE NO LIABILITY FOR ANY INDIRECT, SPECIAL, CONSEQUENTIAL OR INCIDENTAL DAMAGES ARISING FROM OR IN CONNECTION WITH THE USE OR PERFORMANCE OF THE SOFTWARE. THIS LIMITATION SHALL APPLY EVEN IF ANY REMEDY FAILS OF ITS ESSENTIAL PURPOSE. IN NO EVENT SHALL FIAT AUTO S.p.A.’S SOFTWARE SUPPLIERS AND/OR THEIR AFFILIATES BE LIABLE FOR ANY AMOUNT IN EXCESS OF U.S. TWO HUNDRED FIFTY DOLLARS (U.S.\$250.00).
- **FOR APPLICABLE LIMITED WARRANTIES AND SPECIAL PROVISIONS PERTAINING TO YOUR PARTICULAR JURISDICTION, PLEASE REFER TO YOUR WARRANTY BOOKLET INCLUDED WITH THIS PACKAGE OR PROVIDED WITH THE SOFTWARE PRINTED MATERIALS.**





Fiat Group Automobiles S.p.A. - Customer Services - Technical Services - Service Engineering
Largo Senatore G. Agnelli, 5 - 10040 Volvera - Torino (Italia)
Print no. 603.97.217 - 09/2009 - I Edition



The data contained in this publication is intended merely as a guide. FIAT reserves the right to modify the models and versions described in this booklet at any time for technical and commercial reasons. If you have any further questions please consult your FIAT dealer. Printed in recycled paper without chlorine.