

DELTA

DELTA

DELTA

DELTA

DELTA

DELTA

LANCIA 

DELTA

DELTA

DELTA

DELTA

Owner Handbook

QUICK REFERENCE

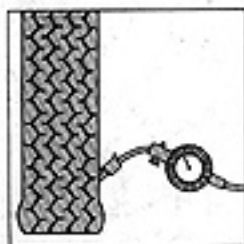

45290

Front and rear tyre pressures (bar)

	Delta 1.5 LX - GT i.e.	Delta HF turbo
Average load	2.0	2.2
Fully laden	2.2	2.4
Spare tyre	2.8	2.8

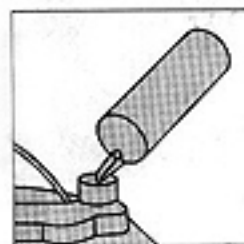

45291

Oil change capacity (litres)

	Delta 1.5 LX	Delta GT i.e.	Delta HF turbo
Sump	4.10	4.50	4.30
Sump + filter	4.30	5.00	4.80



45292

Fuel tank capacity: 57 litres (including a reserve of 6-9 litres).

Either leaded or unleaded petrol (minimum octane no. 95) can be used for all petrol engines.

Congratulations on choosing a LANCIA.

The owner handbook is designed to help you learn about the unique features of your new car. We suggest you read it carefully before driving the car for the first time.

The handbook contains information and suggestions regarding the proper use of your car. After reading it we are sure you will be convinced you've made the right choice.

A service schedule maintenance coupon booklet is supplied along with the handbook. The booklet also contains the warranty certificate and explains the terms of the warranty.

We hope you'll enjoy your new car and drive it with pleasure for many years to come.

LANCIA



CONTENTS

Getting acquainted with your car	5
Driving your car	51
What to do if...	59
Maintenance and servicing	71
Body care and maintenance	89
Specifications	95
Appendix	111
Index	119



GETTING ACQUAINTED WITH YOUR CAR

	Page
Dashboard	6
Keys and ignition	9
Instrument panel	10
Instruments	16
Heating and ventilation	25
Air conditioner	27
Column stalks and controls	30
Individual settings	33
Doors	38
Luggage compartment	41
Bonnet	43
Headlamps	44
Refueling	46
Accessories	46
Sunroof	49
Sound system	50

Note: The number and position of instruments, indicator lights and controls may vary depending on the version.

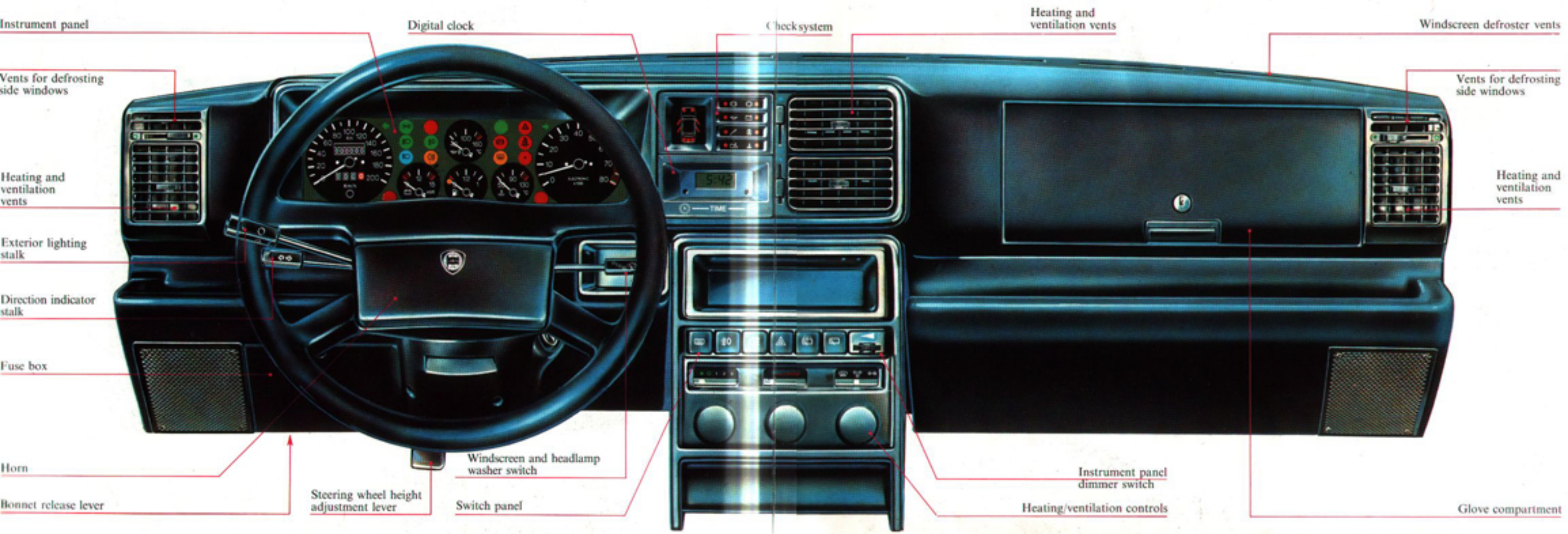

Instrument panel

Digital clock

Check system

Heating and ventilation vents

Windscreen defroster vents

Vents for defrosting side windows

Vents for defrosting side windows

Heating and ventilation vents

Heating and ventilation vents

Exterior lighting stalk

Direction indicator stalk

Fuse box

Horn

Bonnet release lever

Steering wheel height adjustment lever

Windscreen and headlamp washer switch

Switch panel

Instrument panel dimmer switch

Heating/ventilation controls

Glove compartment

KEYS AND IGNITION

Keys

Two keys and duplicates are supplied with the car. Key A is for the doors (including the hatchback), glove compartment and fuel filler door.

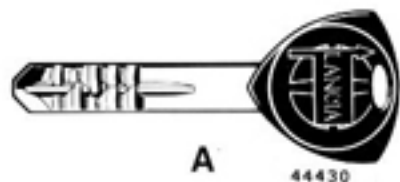

Key B only operates the steering column lock and ignition.

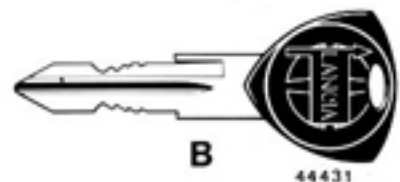

An adhesive tag included with the keys bears the code number necessary for requesting duplicates from your Lancia dealer.

Ignition switch

- STOP – Steering column locked, key can be removed.
- MAR – Driving position, electrical systems energised.
- AVV – Starting.

PARK – Side lights on, steering column locked, key can be removed. Press button A to select PARK.



If the ignition switch has been tampered with (e.g., attempted theft), have it checked at a Lancia Service Centre.

Steering column lock

Locking: When the ignition is at STOP or PARK, turn the steering wheel to the left or right until you hear the lock mechanism click.

Unlocking: Turn the ignition key to MAR while moving the steering wheel slightly in either direction.

Never remove the ignition key when the car is moving. If you do, the steering wheel will lock the first time you turn it.

INSTRUMENT PANEL

Instrument panel (Delta 1.5 LX without check system)

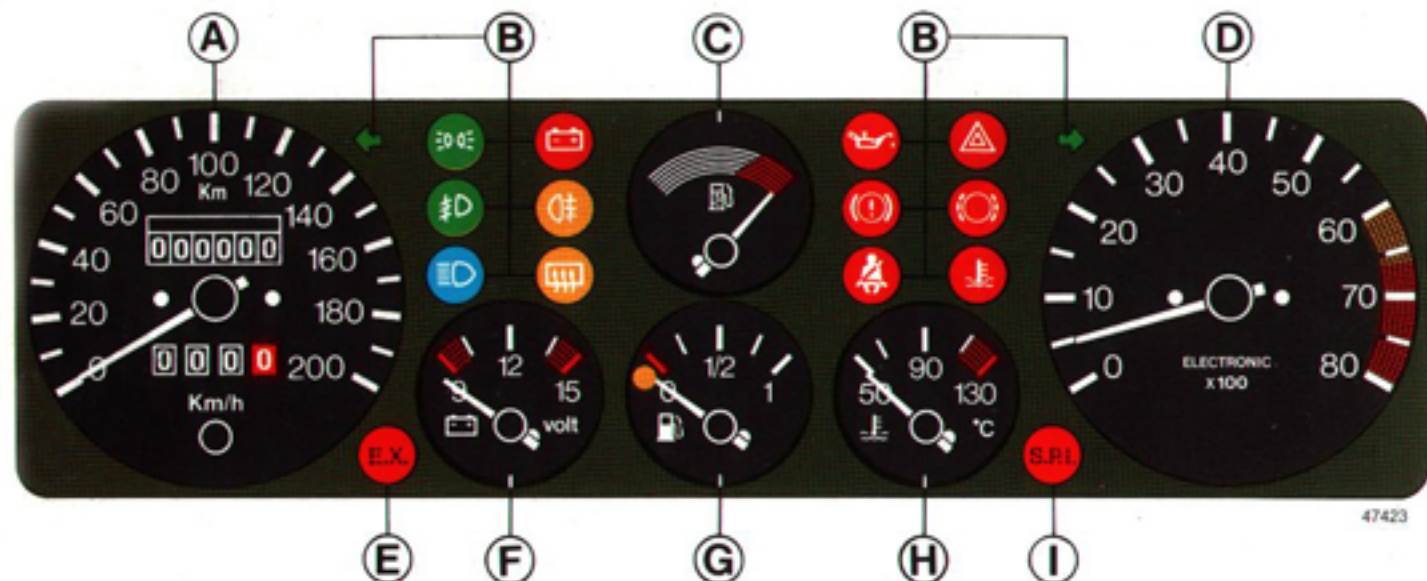

A. Speedometer and odometer. - B. Indicator and warning lights. - C. Fuel economy gauge. - D. Rev counter. - E. Catalytic muffler temperature warning (not all countries). - F. Voltmeter. - G. Fuel gauge. - H. Coolant temperature gauge. - I. Emergency operation of integrated fuel supply/ignition system (not all countries).

INSTRUMENT PANEL

Instrument panel (Delta 1.5 LX with check system)

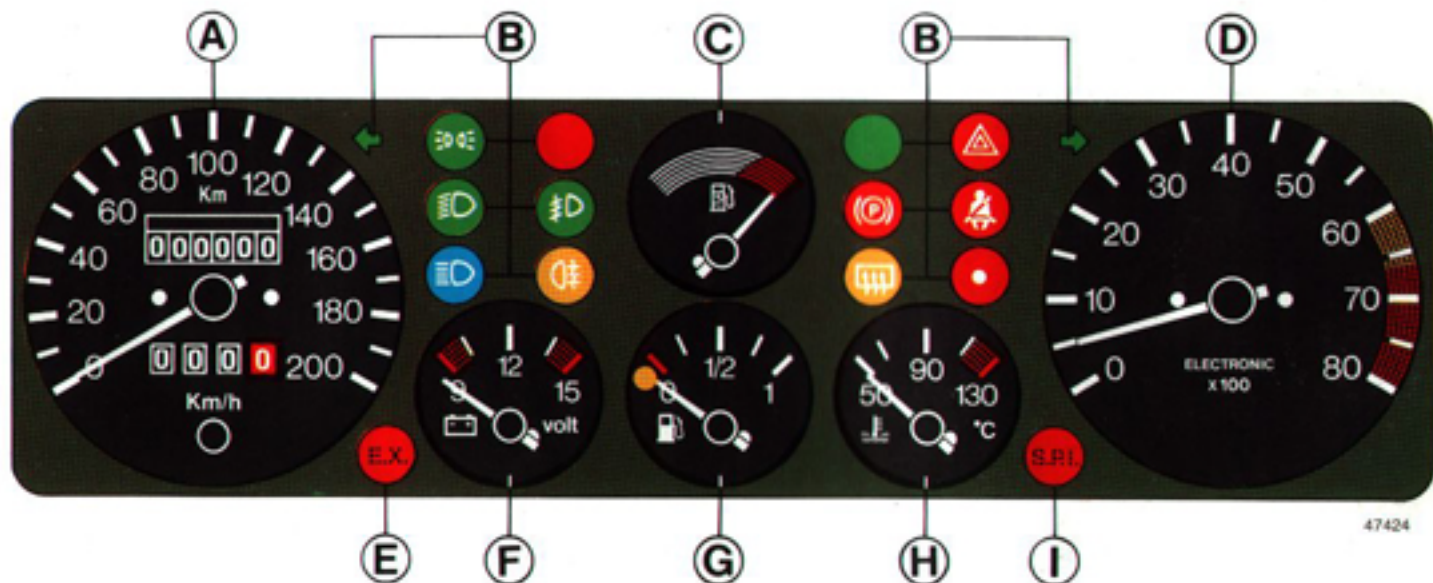

A. Speedometer and odometer. - B. Indicator and warning lights. - C. Fuel economy gauge. - D. Rev counter. - E. Catalytic muffler temperature warning (not all countries). - F. Voltmeter. - G. Fuel gauge. - H. Coolant temperature gauge. - I. Emergency operation of integrated fuel supply/ignition system (not all countries).

INSTRUMENT PANEL

Instrument panel (Delta GT i.e. without check system)

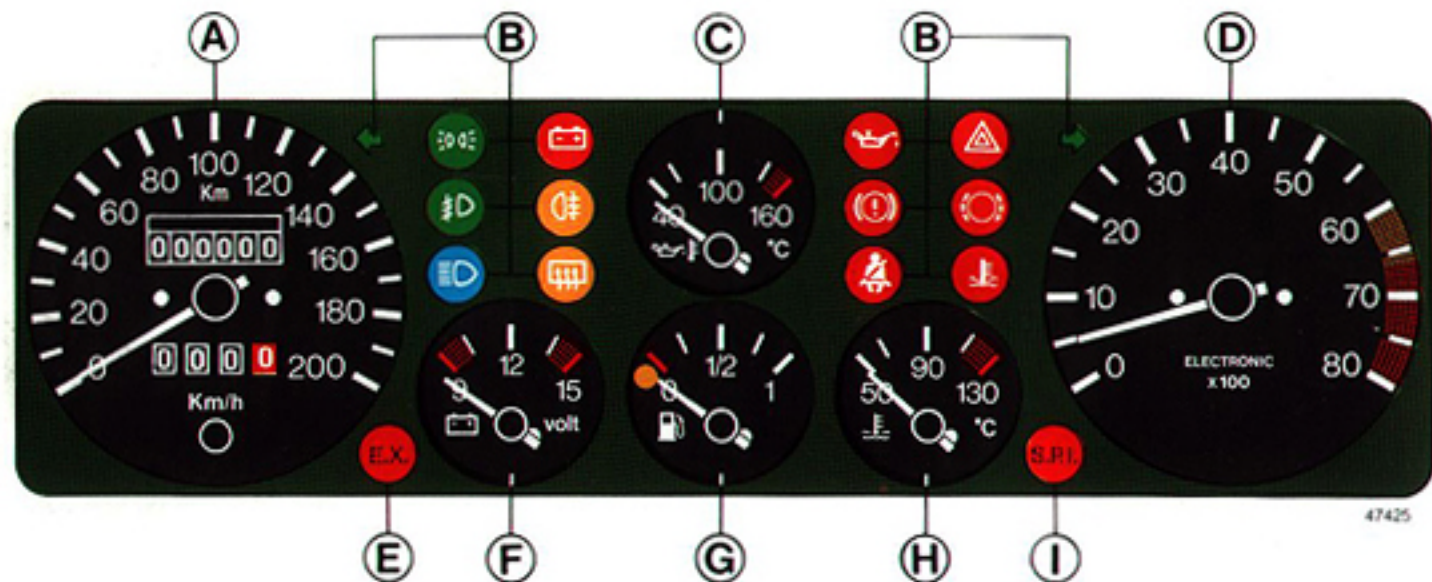

A. Speedometer and odometer. - B. Indicator and warning lights. - C. Oil temperature gauge. - D. Rev counter. - E. Catalytic muffler temperature warning (not all countries). - F. Voltmeter. - G. Fuel gauge. - H. Coolant temperature gauge. - I. Emergency operation of integrated fuel supply/ignition system (not all countries).

INSTRUMENT PANEL

Instrument panel (Delta GT i.e. with check system)

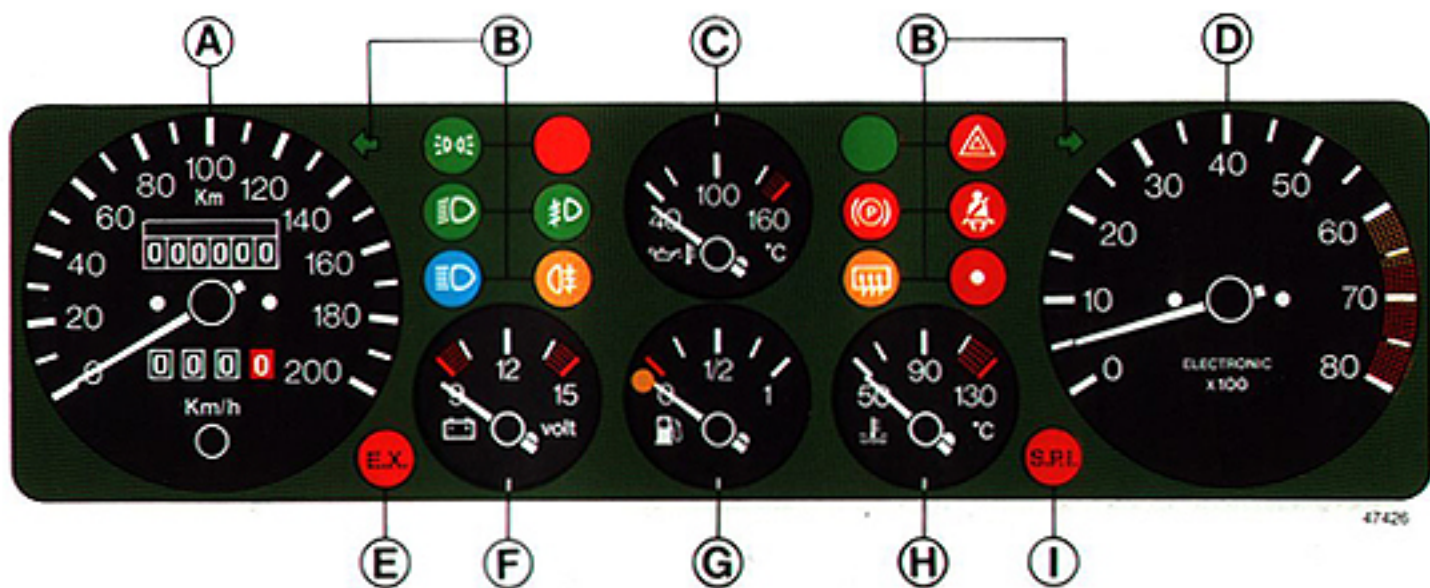

A. Speedometer and odometer. - B. Indicator and warning lights. - C. Oil temperature gauge. - D. Rev counter. - E. Catalytic muffler temperature warning (not all countries). - F. Voltmeter. - G. Fuel gauge. - H. Coolant temperature gauge. - I. Emergency operation of integrated fuel supply/ignition system (not all countries).

INSTRUMENT PANEL

Instrument panel (Delta HF turbo without check system)

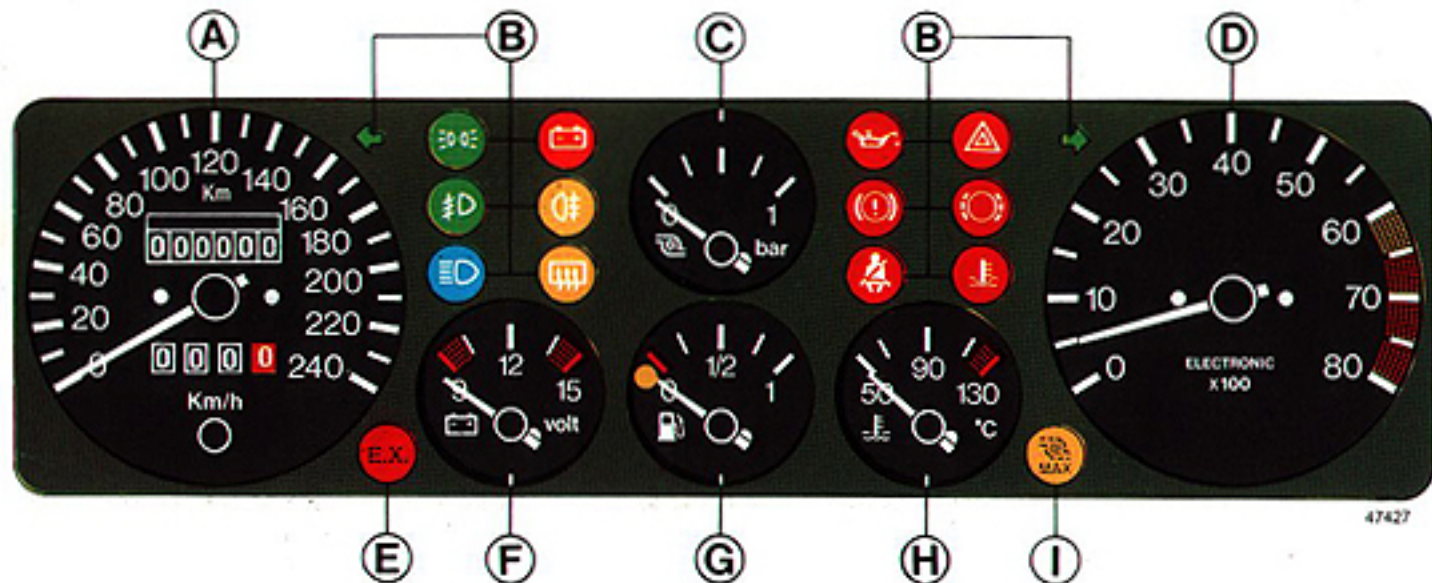

A. Speedometer and odometer. - B. Indicator and warning lights. - C. Turbocharger pressure gauge. - D. Rev counter. - E. Catalytic muffler temperature warning (not all countries). - F. Voltmeter. - G. Fuel gauge. - H. Coolant temperature gauge. - I. Overboost indicator.

INSTRUMENT PANEL

Instrument panel (Delta HF turbo with check system)

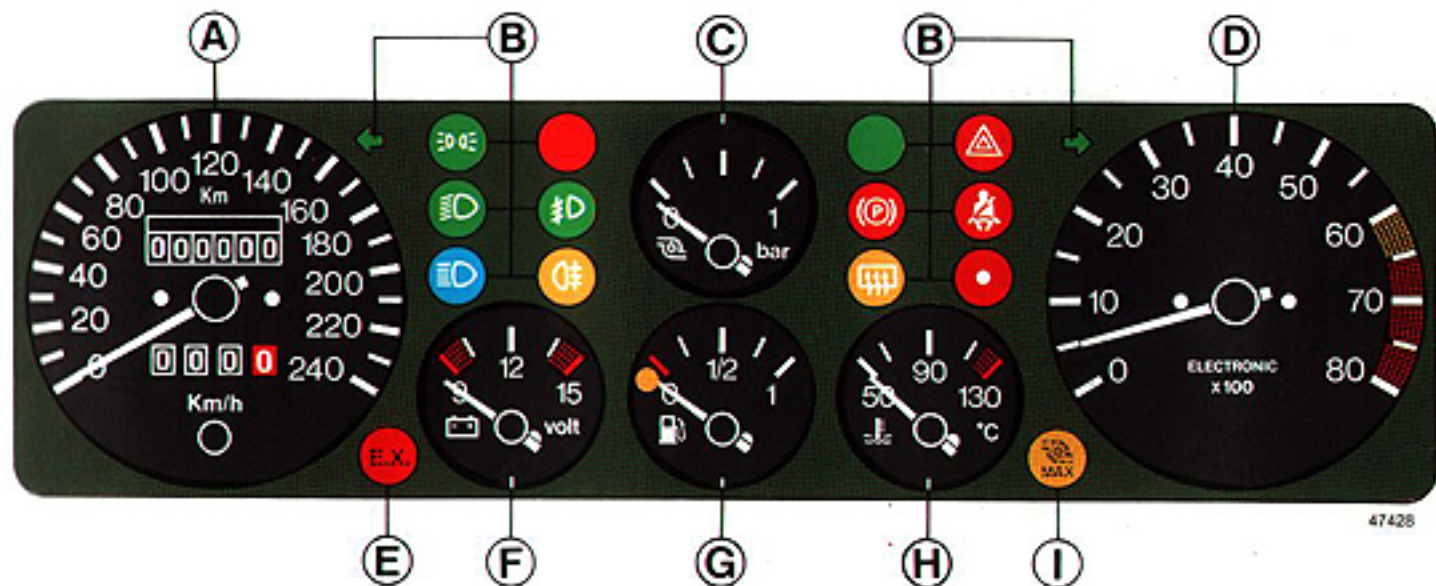

A. Speedometer and odometer. - B. Indicator and warning lights. - C. Turbocharger pressure gauge. - D. Rev counter. - E. Catalytic muffler temperature warning (not all countries). - F. Voltmeter. - G. Fuel gauge. - H. Coolant temperature gauge. - I. Overboost indicator.



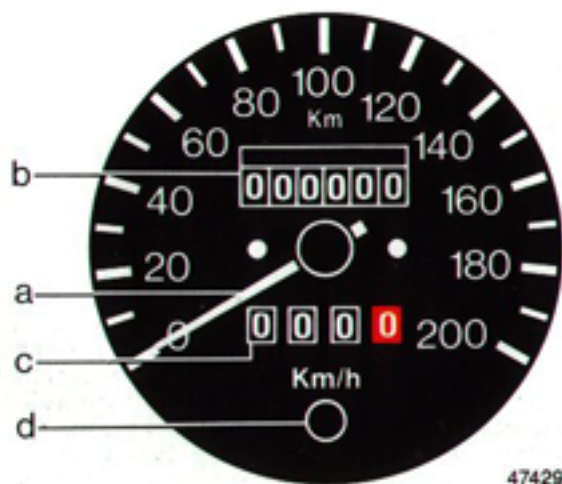

A





- a - Speedometer
- b - Odometer
- c - Trip odometer
- d - Trip odometer zeroing button. Press when car is stationary or moving.

B

Indicator and warning lights

-  Left direction indicator
-  Side light indicator
-  Low beam headlamp indicator
-  High beam headlamp indicator
-  Battery warning

If illuminated, the alternator is malfunctioning. There may be a slight delay in turning off when the engine is idling.

-  Main malfunction warning
- Only for versions with the check system.
-  Fog light indicator
 -  Rear fog-guard light indicator



Oil pressure warning

This warning light turns off as soon as the engine starts (a slight delay is acceptable if the engine is idling).

After a long trip under heavy load conditions the warning light may illuminate. Don't worry, as long as it turns off soon after accelerating slightly.



All systems operative indicator

Only for versions with the check system.



Brake fluid warning and handbrake engaged indicator



Handbrake engaged indicator

Only for versions with the check system.



Rear window defroster indicator



Available indicator position (only versions with the check system)



Hazard warning lights



Brake pad wear warning



Rear window defroster indicator

Only for versions with the check system.



Coolant warning

Indicates the engine is overheating. If it illuminates when driving at speeds higher than 50 km/h, stop the car and press down the accelerator pedal slightly. If the warning light remains illuminated, switch off the engine. If the warning light is on when the engine is idling or when driving slowly, follow the same procedure described above. If, however, the temperature continues to rise, switch off the engine and have the car towed to a Lancia Service Centre.



Seat belt warning (driver's belt not buckled)



Right direction indicator

C

Fuel economy gauge

This instrument gives a rough indication of fuel consumption.



47439

If you are able to maintain the needle in the white sector, consumption will be low.

When you accelerate rapidly the needle will enter the red sector indicating high fuel consumption. To save fuel, slow down or shift up to a higher gear.

Turbocharger pressure gauge (scale in bar)



47433

When this gauge constantly indicates pressure values above 0.85 bar release the accelerator until the pressure returns to lower values. In any case, have your car checked at a Lancia Service Centre.

Oil temperature gauge (°C)



47432

INSTRUMENTS

When the oil temperature is too high (needle in red sector), stop the car, but let the engine idle for a few minutes until the oil temperature returns to lower values. If this does not happen, switch off the engine and have the car towed to a Lancia Service Centre.

D

Rev counter



The engine is at maximum power when the needle is in the yellow zone. Driving at higher engine speeds will not provide higher performance, but no engine damage will occur. Drive only briefly at red-zone speeds.

E

Catalytic muffler temperature warning

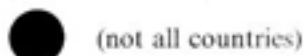

F

Voltmeter

The instrument should indicate a voltage value between 12.5 and 12.8 (key at MAR) when the battery is properly charged.



When the engine is running the voltmeter will indicate values between 14 and 15 volts. The voltmeter is accurate to ± 0.3 volts.

G

Fuel gauge (litres)

The fuel tank has a capacity of 57 litres.



Low fuel warning light A illuminates when only 6-9 litres of fuel remain in the tank. If you have a check system, see p. 21 for information regarding this warning light.

H

Coolant temperature gauge (°C)

The needle will be at the left side of the scale when the engine is cold. Under normal operating conditions the needle should be at the centre of the scale. Red zone values indicate the engine is labouring. If gauge indicates the engine is overheating, drive at a lower engine speed (rpm).

If the temperature does not start dropping when driving at a lower engine speed and the needle enters the red zone, stop the car immediately and have it towed to a Lancia Service Centre.



I

Emergency operation of integrated fuel supply/ignition system warning (not all countries)

- When this warning light illuminates, call your dealer or a Lancia Service Centre for more information.

Overboost indicator

- (see p. 100)

Check system

The check system is an electronic instrument that monitors and displays malfunctions that can affect vehicle operation and safety.

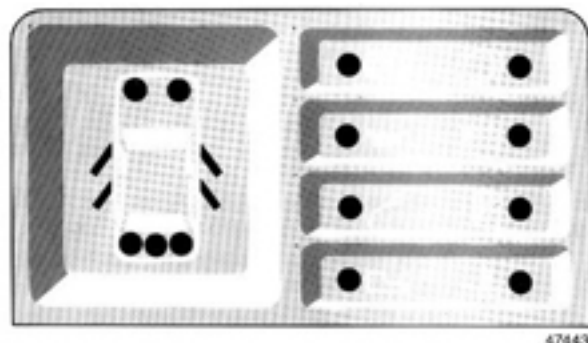

When systems are operating properly

- Turn the key to MAR. All the check system lights (including fuel reserve warning and green “all systems operative” indicator) illuminate (see p. 17).
- Start the engine. All warning lights should turn off within 7 seconds.

Notes:

- When pressing the brake pedal or turning on the side lights and rear fog-guard lights none of the red warning lights should turn back on.
- High-speed cornering, sudden braking, rapid acceleration or driving on poorly surfaced roads may cause some of the warning lights to illuminate (e.g., coolant and brake fluid).
- If the car is started on a grade, the oil warning light may illuminate. Because this indication is stored in system memory, you must start the car again on level ground to ensure there is sufficient oil in the lubrication system.

When malfunction occurs

- All the warning lights (including fuel reserve and main malfunction warning) illuminate when you turn the key to MAR (see p. 16).
- When the engine starts, all the panel lights of operative devices or systems turn off within 7 seconds. Only those warning lights regarding malfunctions and the main malfunction warning light remain on.

Panel warning light

Malfunction



Doors not closed. Door open is indicated on the panel.



Side light failure. When you turn on the side lights, a panel indicator at the front of the car illuminates (bulb burned out or wiring malfunction).

Taillight failure. When the taillights are on, the panel indicators located at the back of the car illuminate (bulb burned out or wiring malfunction).

The check system does not indicate when all the side/taillights are off due to both their fuses blowing at the same time. Therefore, occasionally make a visual check of exterior lights.



The illumination of two opposite diagonal panel lights indicates a blown common fuse, two burned-out light bulbs, or a wiring malfunction.

Panel warning light

Malfunction



Stop light failure. The panel light corresponding to the burned-out bulb illuminates. When a single bulb burns out or wiring malfunction occurs, the panel indicator turns on only about 2 seconds after pressing down the brake pedal.

If both stop lights burn out (or a wiring malfunction occurs) both panel brake light indicators turn on at the same time without pressing the brake pedal.

Stop light switch failure. If the stop light switch fails causing the stop light to remain off, both stop light panel indicators turn on 2 seconds after pressing down the brake pedal.

If the switch is simply malfunctioning, but the stop lights illuminate when braking, both stop light panel indicators illuminate (or remain on). The panel light turns off when you release the brake pedal.



Rear fog-guard light failure. When the fog-guard lights are turned on, the panel indicator illuminates when there is a burned-out bulb(s) or wiring malfunction between the fuse and light bulbs.

Panel warning

Malfunction



If this light illuminates when the engine is running, alternator output is insufficient or there is a recharging circuit malfunction.



Low coolant level, sensor failure or wiring malfunction.



Low brake fluid level, sensor failure or wiring malfunction.



Brake pads worn. Slight wear is indicated only when the brake pedal is pressed down.



Low oil level, sensor failure or wiring malfunction. Engine lubricant monitoring occurs when the key is turned to MAR before starting the engine (see note on p. 21), but is indicated only when the engine is running. No oil level monitoring occurs while driving.



Low oil pressure, sensor failure or wiring malfunction.

Panel warning light

Malfunction



Available warning light position



Coolant temperature warning.

Digital clock

The 24-hour digital clock displays the time in hours and minutes. Display lighting automatically adjusts to surrounding light conditions when turning the exterior lights on and off.

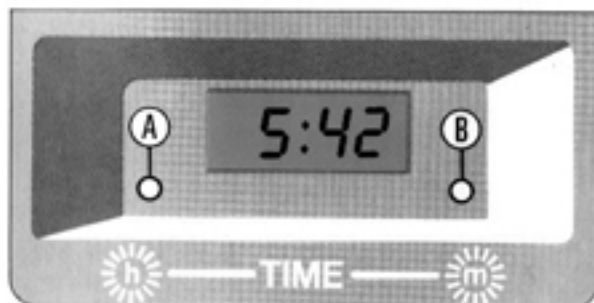

47451

To change the hour: Press button A.

To change the minutes: Press button B.

Each time you press one of the buttons the clock will advance one hour or one minute. Hold the button(s) down to advance rapidly, then release when you have nearly reached the correct time.

Oil pressure and temperature gauges

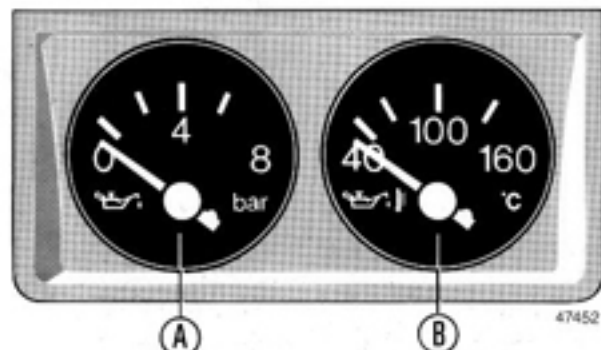

Some versions have an oil pressure gauge A and oil temperature gauge B next to the main instrument panel.

A Oil pressure gauge (scale in bar)

When the engine is hot the oil pressure should be between 3.5 and 5 bar.

When idling (engine hot), the gauge may indicate pressures below 2 bar. When accelerating slightly, the pressure should rise.

After starting the engine during winter oil pressure values may be higher than normal. Do not accelerate rapidly. Wait until the oil pressure stabilizes.

If the oil pressure indicated is too high or low, switch off the engine and have your car taken to a Lancia Service Centre.

B Oil temperature gauge (°C)

When the gauge indicates the oil temperature is too high (red zone), stop the car but do not switch off the engine. Let the engine idle for a couple of minutes. If the temperature does not drop, switch off the engine and have your car taken to a Lancia Service Centre.

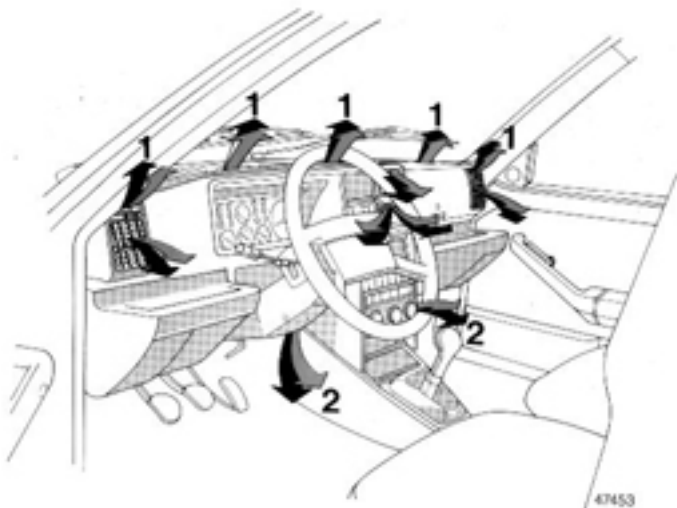

Stationary vents

- 1 - Windscreen and side windows.
- 2 - Front passenger footwells.

Adjustable vents

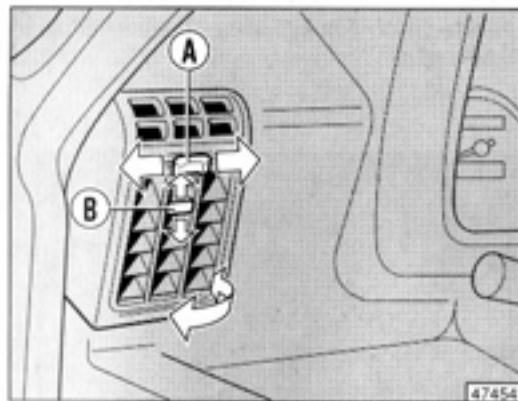

A - Vent opening and closing:

● = Vent closed.

○ = Vent open.

B - Use to direct the air flow horizontally.

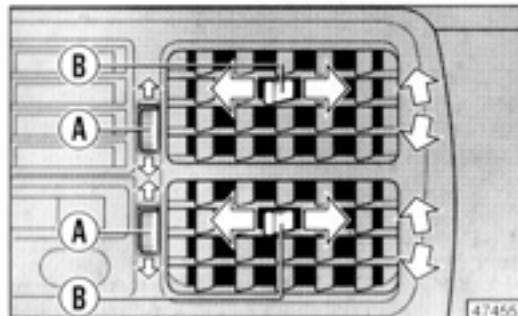

HEATING AND VENTILATION

Controls

The three heating and ventilation system knobs are located on the centre console.

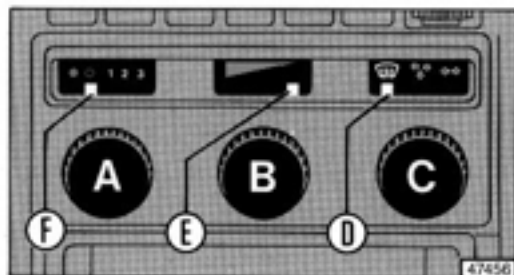

Knob A = Fan speed selector.

When the knob pointer F is at ● the system and fan are off.
When knob pointer F is at ○ air can enter the passenger compartment (fan off).

When the car is standing or when you're driving slowly, three different fan speeds may be selected.

- 1 = Low.
- 2 = Medium.
- 3 = High.

The fan only operates when the key is at MAR.



Knob B = Air temperature.

Pointer E at left = Outside air.

Pointer E at right = Maximum heating.

Use intermediate positions to provide optimal passenger comfort while driving.

Knob C = Air distribution selector. The three knob positions are:

-  = Air directed only to windscreen.
-  = Air directed to all vents for maximum comfort (manual regulation possible).
-  = Air directed only to dashboard vents.

Defrosting and defogging

Set the knobs to the positions indicated in the figure at left for windscreen defrosting or defogging.

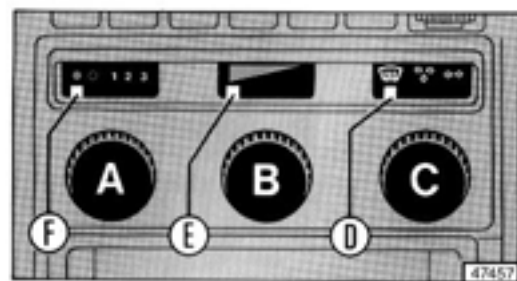

When the outside temperature is below -5°C , don't use a fan speed higher than 2 to prevent the air from cooling before reaching the windscreen.

Heating

Turn knob A so that pointer F is under 0, then turn knob B so that pointer E is at the right.

Turn the fan knob to 1 or 2 for rapid heating.

To make heating more efficient, air can be directed to vents 1 and 2 (see figure at right) by turning knob C so that its pointer D is under .

Ventilation

Turn knob B so that pointer E is fully to the left for ventilation. Use the other settings described for heating.

Air conditioner (optional)

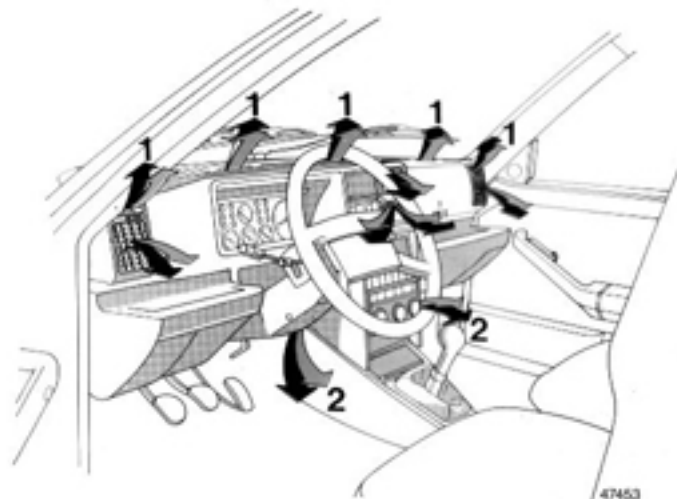

Stationary vents

- 1 - Windscreen and side windows.
- 2 - Front passenger footwells.

AIR CONDITIONER

Adjustable vents

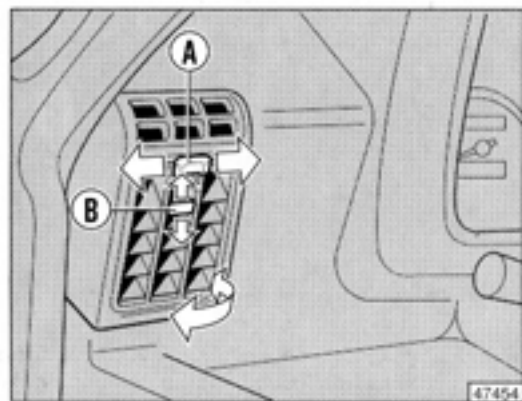

A - Vent opening and closing:

● = Vent closed.

○ = Vent open.

B - Use to direct the air flow horizontally.

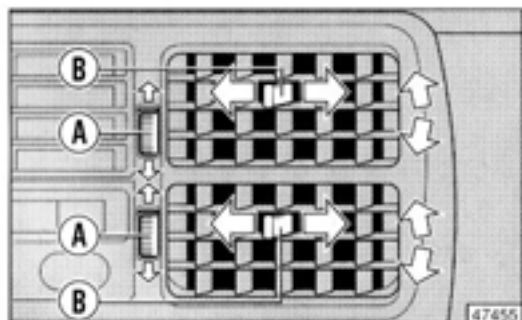

Controls

The system controls consist of three knobs and two push buttons located on the centre console.

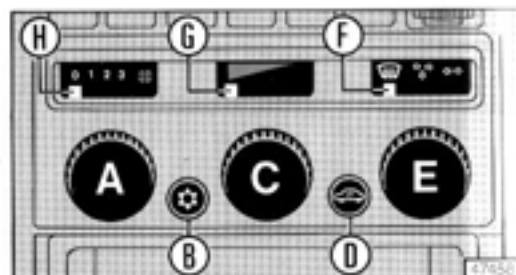

Knob A = Fan speed selector.

1 = Low.

2 = Medium.

3 = High.

The fan will only operate when the ignition key is turned to MAR.

Button B = Air conditioner ON/OFF switch (fan operates at low speed when the air conditioning is turned on).

AIR CONDITIONER

Knob C = Air temperature control.

Pointer G at left = Outside air.

Pointer G at right = Maximum heating.

Use intermediate positions for optimal passenger comfort.

Button D = Recirculation.

No outside air enters the passenger compartment when this button is pressed.

Knob E = Air distribution selector. Pointer F may be set to one of the following three positions:

 = Windscreen.

 = All vents (manual regulation possible).

 = Dashboard vents only.

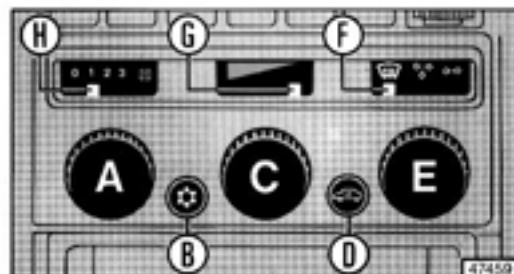

Defogging and defrosting

Set the controls as indicated below for rapid defogging or defrosting.

Knob A : 3.

Button B : Press in.

Pointer G : Right.

Button D : Press in.

Pointer F : At .

Leave button D in (air recirculates) until the maximum temperature is reached, then press it again to prevent the windows from fogging up.

Heating

Set the controls as indicated below for gradual heating or to maintain the temperature after defrosting.

Knob A : Select fan speed desired.

Button B : Press in.

Pointer G : Select position for temperature desired.

Button D : Recirculation off.

Pointer F : At  or .

COLUMN STALKS AND CONTROLS

Air conditioning

Use the same settings listed for heating, except turn knob C so that pointer G is at the left.

Set the controls as follows for maximum cooling:

Knob	A : 3.
Button	B : Press in.
Pointer	G : Left.
Button	D : Press in.
Pointer	F : At \odot .

Switches

Switch panel lighting (as well as cigarette lighter and instrument panel lights) turns on whenever you turn on the side lights.

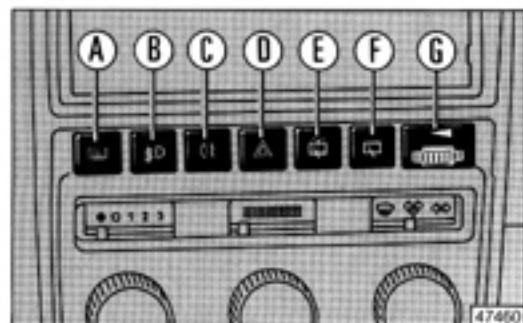

Rear window defroster

Press button A to defog or defrost the rear window.

Fog lamps (if fitted)

Press button B when the headlights are on (key at MAR).

Rear fog-guard lights

Press button C when headlights or front fog lights are on (key at MAR).

Hazard warning lights

Press button D (key not necessary). All the direction indicators lights flash.

Rear window wiper/washer

Press button E (key at MAR) to turn on both the rear window wiper and washer. Press button F to turn on only the wiper.

Instrument panel dimmer



Use knurled thumbwheel G to adjust instrument panel light intensity.

COLUMN STALKS AND CONTROLS

Exterior light stalk

The lights described below can be turned on when the ignition key is at MAR.



Pull the stalk toward the steering column to flash the high beam headlamps (panel indicator  also turns on).

Side lights: Turn the stalk from  to . Panel indicator  also turns on.

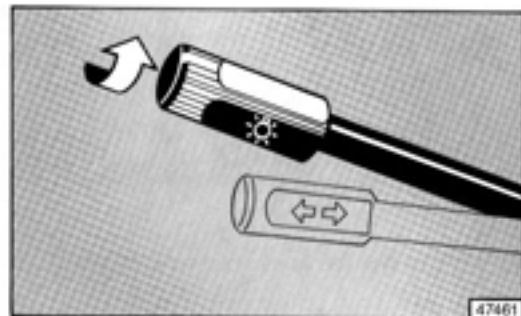
Refer to p. 9 for information regarding the parking lights.



The stalk cannot be pulled down from this position.

Low beam headlamps: Turn the stalk from  to .

Panel indicator  also turns on.

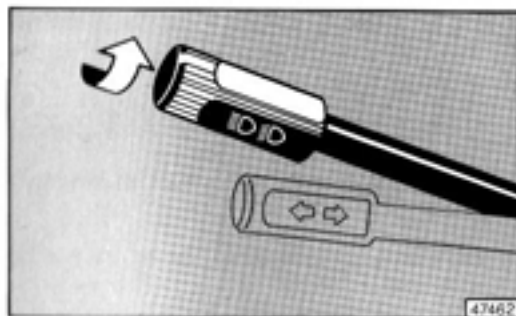

High beam headlamps: Move stalk down when at .

The high beam panel indicator  also turns on.

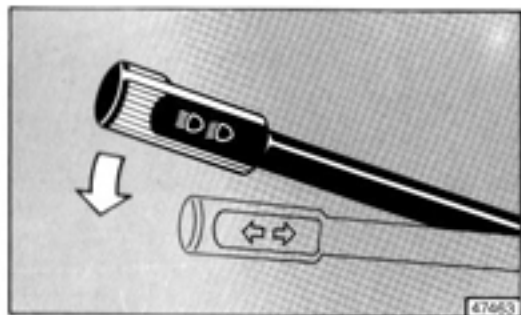

The stalk cannot be turned from this position.

Direction indicators

The key must be at the MAR position to use the direction indicators.

Move the stalk

Up = Right turn ( flashes).

Down = Left turn ( flashes).

The stalk automatically returns to the centre position after completing the turn.

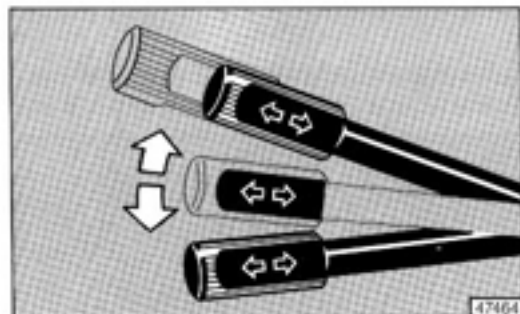

To indicate a lane change requiring only a small turn of the steering wheel, press the stalk slightly up or down. When you release it the stalk returns to the centre position.

Windscreen wiper/washer stalk

The windscreen wiper/washer operates only when the key is at MAR.

0 = OFF.

1 = Intermittent operation.

2 = Slow continuous operation.

3 = Fast continuous operation.

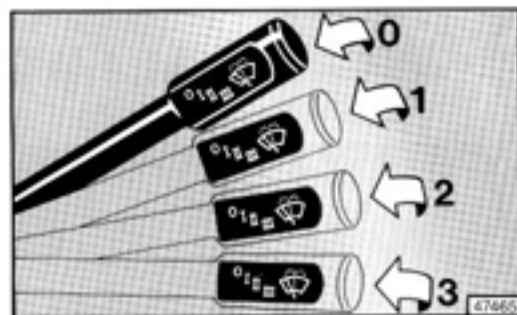

Pull the stalk toward the steering wheel to wash the windscreen.

The wiper blades automatically return to the base of the windscreen when turned off.

Steering wheel adjustment

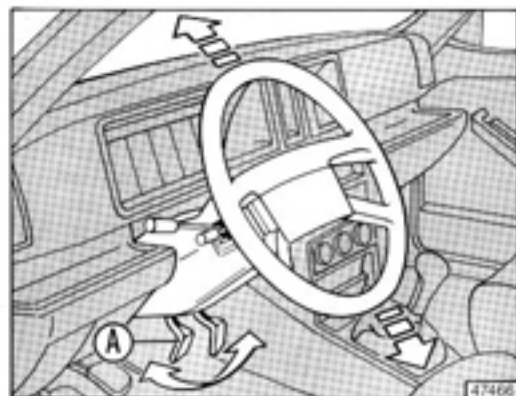

The height of the steering wheel can be adjusted by pulling out lever A. When you have set the wheel to a comfortable height press the lever fully back.

Rearview mirrors

Adjust your seat to a comfortable position for driving, then adjust the mirrors.

Interior rearview mirror

The mirror is adjustable. Use lever B to select the antiglare position.

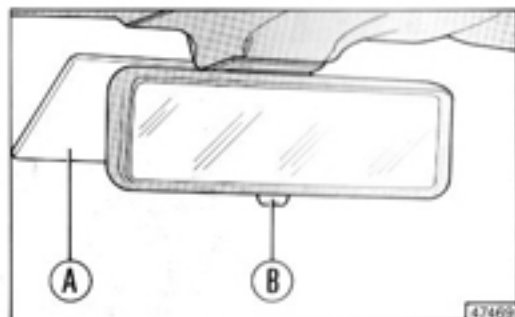

For safety reasons the mirror will release if an impact occurs. Registration and insurance certificate holder A can be removed after pulling up the mirror (Italy only).

INDIVIDUAL SETTINGS

Door mirrors

Use knob A to adjust the mirrors.



Front seats



Pull up lever B, then exert body pressure in the direction desired to adjust the seat's fore-and-aft position.

Use knob A to adjust the backrest.

The height and tilt of the headrests can be adjusted. The headrest should always support the back of your head, not your neck.

Some versions are equipped with anatomic seats featuring an adjustable seat cushion. Use lever C to increase/decrease the length of the cushion.

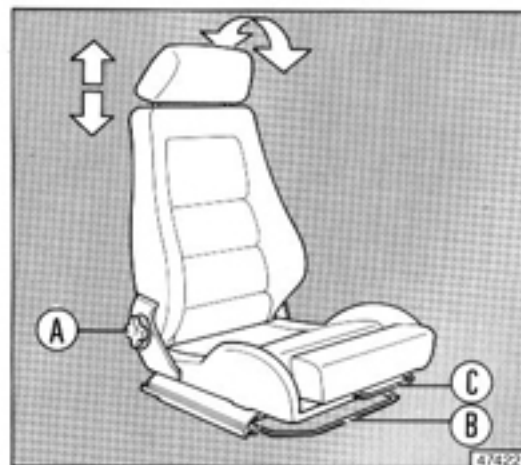

INDIVIDUAL SETTINGS

Seat belt and child restraint information

All vehicle occupants are required to respect the Motor Vehicle Code provisions regarding seat belt installation and use in the country where the car is driven.

Although not always obligatory, it is highly recommended all occupants exempted from using seat belts sit on the back seat or use a restraint system.

All minors whose physical features (weight, age, height) are under legal limits in the country where the car is driven must be protected by approved *universal* restraints (carrier, child seat or booster cushion) that comply with ECE/ONU regulation 44.

Local legislation applies in those countries which have not adopted regulation 44.

Use of *semiuniversal* or *specific* restraint systems requiring supplementary anchorage points may be installed only if the manufacturer's approval is granted. All vehicle registration forms must be updated by the appropriate government agency after approval testing of the anchorages.

Carefully follow the manufacturer's installation and use instructions supplied with the systems.

A child should never be carried on a passenger's lap with a belt around the child and seat occupant.

Ensure the belt webbing is not twisted. Seat belts should always be worn across the hips, not the abdomen, to avoid sliding forward.

Occasionally check that the anchorage hardware is secured properly. The belt webbing should never be cut or fraying. After a moderate-to-severe collision, it is recommended that the seat belts be replaced, even if there is no apparent damage.

Wash the belts with warm soapy water. Rinse them and let them dry in the shade (never in direct sunlight). Do not use strong detergents, bleach, dyes or any chemical which could weaken the webbing fibres.

INDIVIDUAL SETTINGS

Using the automatic seat belts (front and outer rear positions)

Pull tongue A and insert it into buckle B until you hear a click. Press C to release the belt. Press D to lock the belt.

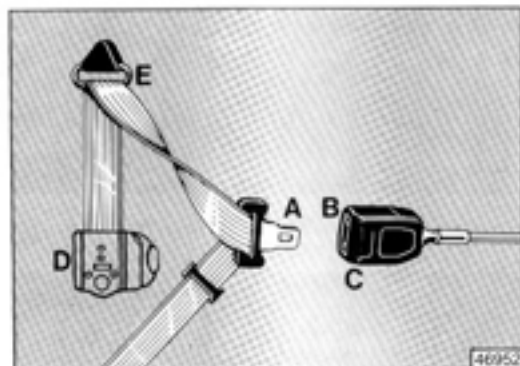

No manual adjustment of these belts is necessary. The webbing unwinds from retractor D located under the pillar trim panel and then passes through loop E. The belt adjusts automatically to the wearer providing ample freedom of movement.

The retractor mechanism may lock if the webbing is pulled out too rapidly or when cornering at high speeds, braking or accelerating rapidly, or when driving on steep grades.

Using the rear seat belts

The belts should be worn as shown in the illustration below.

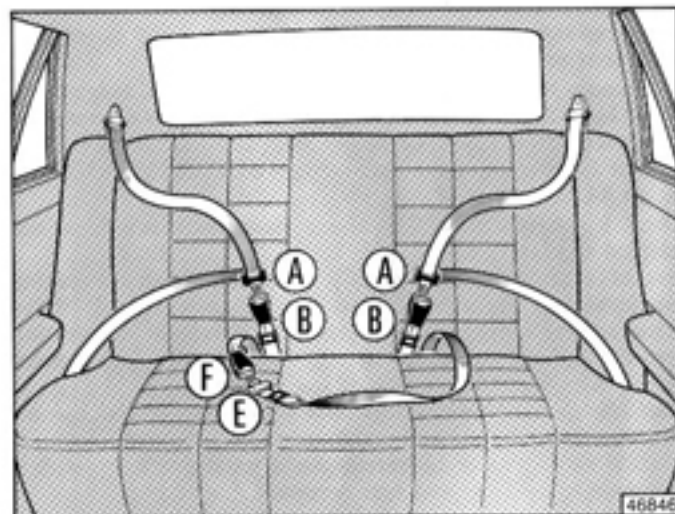

To ensure passengers buckle their belts correctly, tongues A (outer belts) cannot be inserted in buckle F and, vice versa, tongue E will not fit in buckle B.

INDIVIDUAL SETTINGS

Using the lap belt (rear centre position)

The passenger should sit upright against the seat backrest. Insert tongue E into buckle F until it clicks. Press G to release the belt.

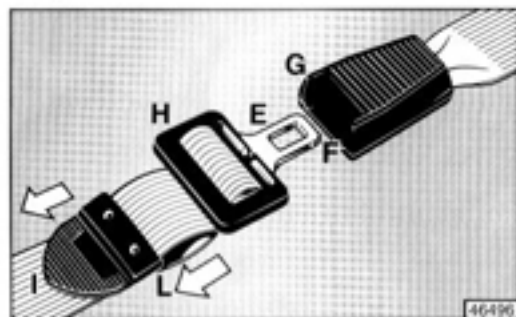

To adjust the length of the belt, pull the webbing through H. Pull at I to tighten or at L to loosen.

The belt is properly adjusted when a closed fist can be placed between the passenger and the webbing.

DOORS

Front side doors

Opening from the outside: Turn key to position 2 and pull the handle.

Locking from the outside: Turn the key to position 1.

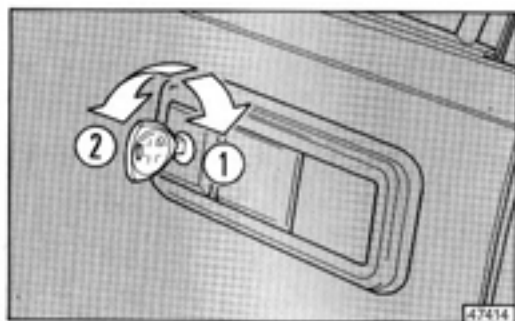

Opening from the inside: Pull lever A up.

Locking from the inside: Press lock button B after closing the door.

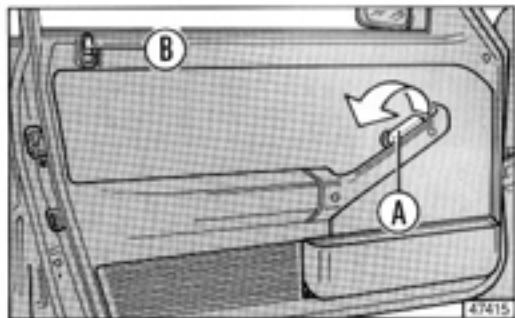

Rear side doors

Opening from the outside: Use the door handle (lock button C must be up).

Opening from the inside: Pull up lock button C, then lever D. If you push down lock button C, the door locks when you close it.

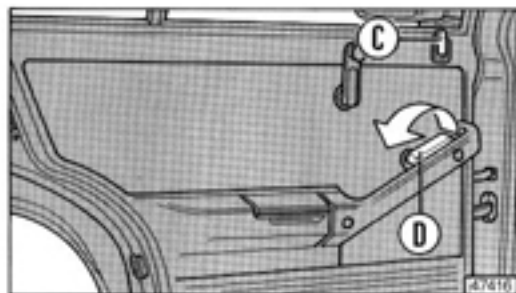

Childproof locks (rear doors only)

1 - Locked. The doors cannot be opened from the inside.

2 - Unlocked.

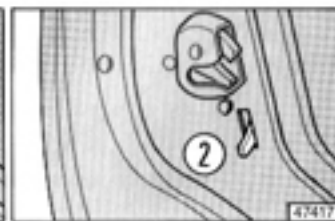
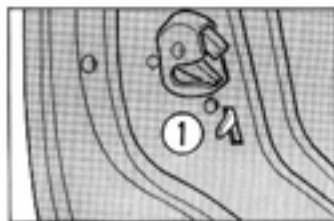

The childproof locks remain engaged even if the rear doors are opened automatically using the power lock system.

Hatchback door

Unlock using the key. Pull handle C up, then open the hatchback. The door will remain in the fully open position.

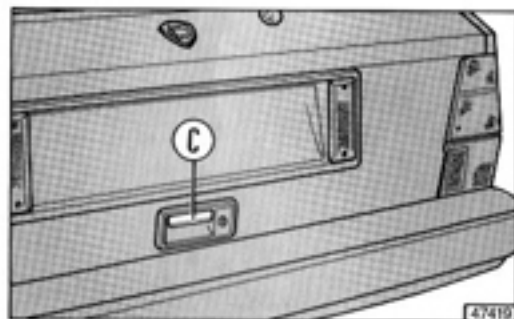

To close the hatchback, press it downwards until it is about 20 - 25 cm from the lock and let it drop. Lock the door using the key.

The gas-filled struts which assist in hatchback door opening are calibrated to operate at the current door weight. Attaching items such as a spoiler or speakers may prevent the door from operating properly.

Power door locks (if fitted)

All doors lock whenever either of the front doors are locked from the outside using the key or from the inside using the lock button.

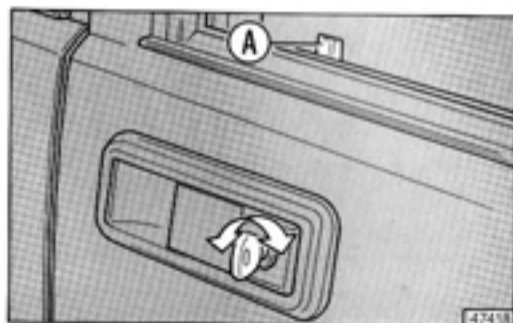

If either of the front doors is unlocked from the outside using the key (or from the inside using lock button A) all of the other doors unlock.

Disconnecting the battery may cause the doors to lock. For this reason, make sure you have not left your keys in the car or leave a door open before disconnecting the battery.

DOORS

Front power windows

A - Left window switch (located near the handbrake lever).

B - Right window switch (located near the handbrake lever).

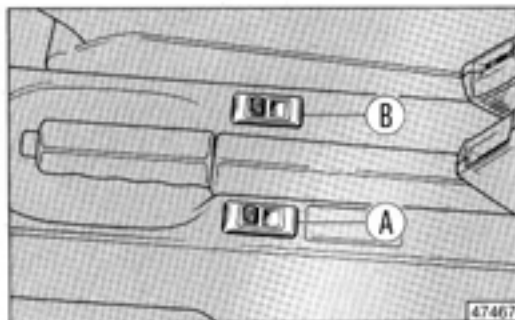

Because power windows can be dangerous if used improperly, always remove the key when leaving your children in the car.

LUGGAGE COMPARTMENT

Increasing the cargo area

Pull handle A to release the seat cushion and then pull it forward.

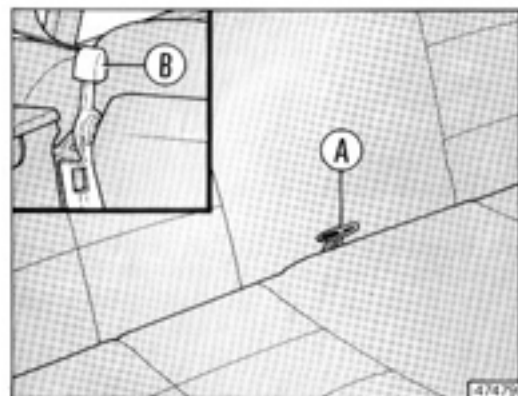

Release the backrest using levers B (one on each side).

The rear shelf can be removed. When the hatchback is closed it covers the luggage compartment and can be used to carry light items.

To make it easier to fold down the seats, remove the rear shelf by releasing cords C at points D, then pull the hinge pegs out of recesses E.

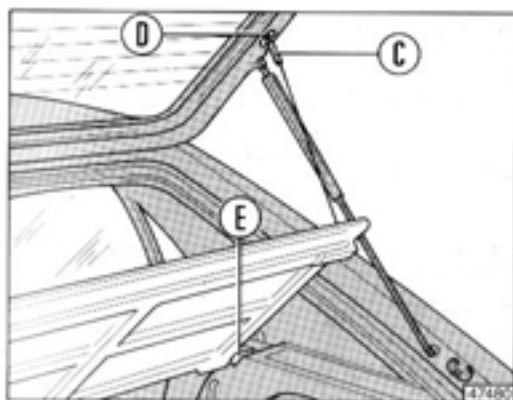

If you need to carry bulky items, cords C can be hooked to recesses F to hold the shelf in a vertical position.

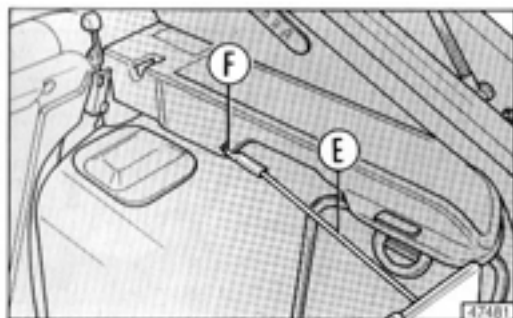

LUGGAGE COMPARTMENT

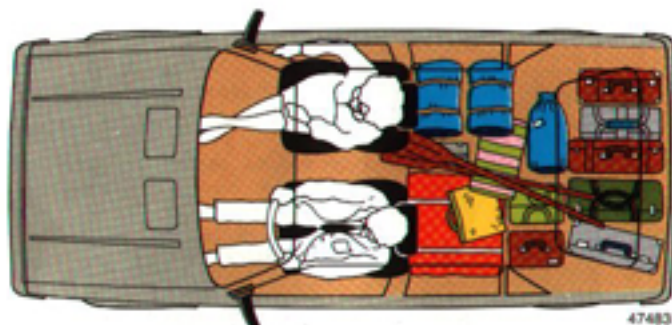

Use the same procedure as described for the bench seat cushion.

If your car has split rear seats, the cargo area can be increased as shown in the two figures.

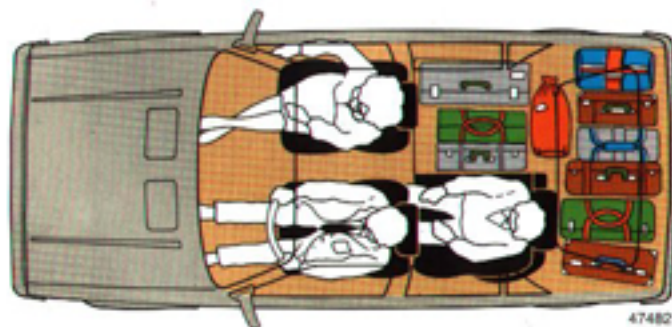

BONNET

Opening and closing

Pull lever B to release the bonnet.

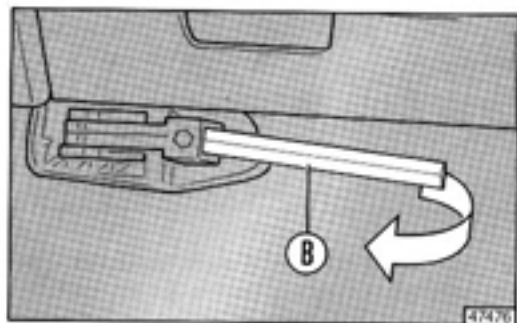

Lift the bonnet. Then, pull rod C out of holder E. When the bonnet is raised insert the tip of support rod C in the recess located in the lid.

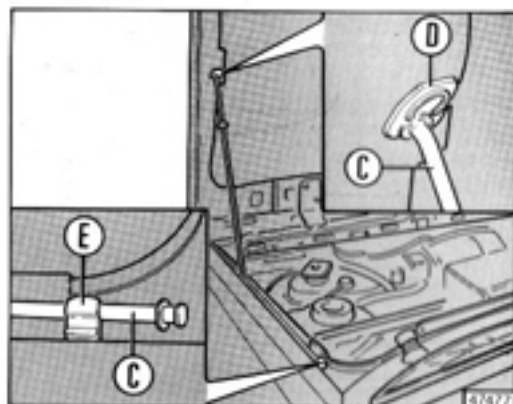

Do this carefully to prevent the bonnet from falling accidentally.

Because the radiator fan is not affected by the position of the ignition key it may continue to operate even after removing the key (e.g., when the engine is very hot). Wait a couple of minutes until it stops before putting your hands in the engine compartment.

Before closing the bonnet replace rod C in holder E. Lower the bonnet holding it at the centre. Let it drop from a height of about 20-25 cm.

HEADLAMPS

Aligning the headlamp beams

Proper headlight alignment is extremely important for safe vehicle operation and the safety of other drivers. Headlamp beam alignment patterns are generally regulated by the Motor Vehicle Code in the country where the car is registered.

Park the car when **unladen** (tyres at recommended pressures - see inside front cover of this handbook) on level ground in front of a light-coloured wall in the shade.

Make sure that the knobs containing screws A are both turned fully clockwise.

If your car has beam compensators that can be adjusted from the driver's seat, place the knob at "0".

Draw two crosses on the wall corresponding to the centres of the beams.

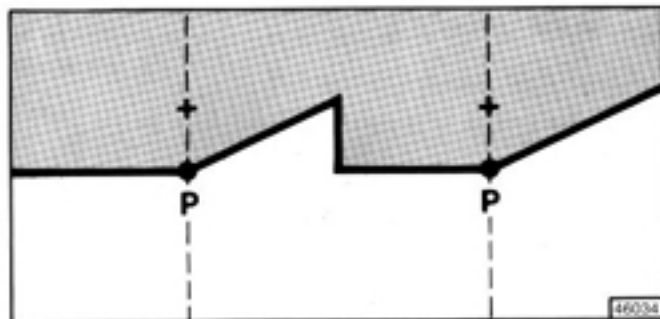
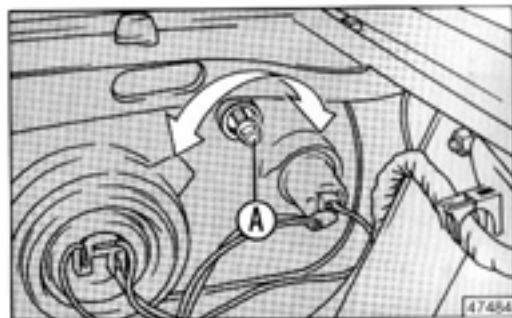

Back up 10 metres from the wall. Reference points P-P should now be about 10 cm below the crosses.

Turn screw A incorporated in the knob to make vertical (up/down) adjustments. Turn screw B to make horizontal (right/left) adjustments.

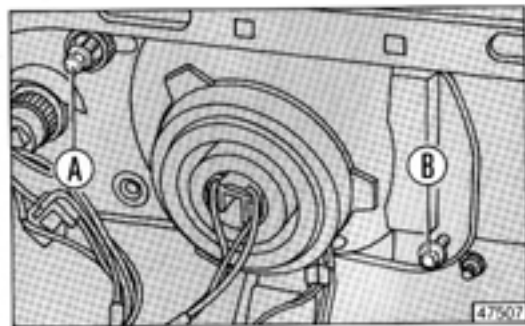

HEADLAMPS

Only limited adjustments can be made. Never attempt to turn the screws past the point where they stop to prevent damaging the headlamps.

The compensator knobs have two positions that can be selected depending on the load you are carrying.

- Turn the knobs clockwise for light-to-average loads.
- Turn the knobs counterclockwise when the car is fully laden.

Always set both headlamp compensator knobs to the same position.

Beam compensation from inside the car (if fitted)

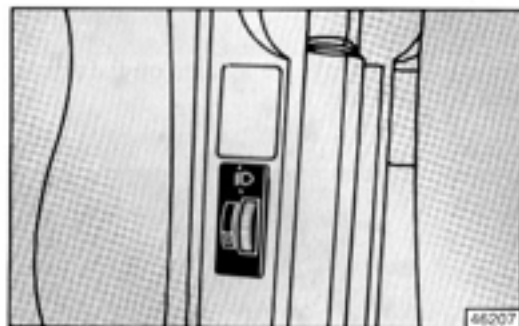

If your car has this feature there is a knob located on the centre console controlling actuators on the headlamps able to change the beam height depending on the weight of the load and where it is being carried in the car.

The knob has four positions from "0" to "3". Refer to the table below.

Knob position	Location of load	
	Delta 1.5 LX - GT i.e.	Delta HF turbo
0	<ul style="list-style-type: none">- Driver only.- Driver and front seat passenger.	<ul style="list-style-type: none">- Driver only.- Driver and front seat passenger.
1	<ul style="list-style-type: none">- Do not use.	<ul style="list-style-type: none">- Driver and max. 75 kg in luggage compartment.
2	<ul style="list-style-type: none">- 5 occupants.- Driver and max. 75 kg in luggage compartment.	<ul style="list-style-type: none">- 5 occupants.- 5 occupants and max. 75 kg in luggage compartment.
3	<ul style="list-style-type: none">- 5 occupants and max. 75 kg in luggage compartment.- Driver and max. 200 kg in luggage compartment.- Driver and load placed centrally on folded rear seat (max. 280 kg).	<ul style="list-style-type: none">- Driver and max. 200 kg in luggage compartment.- Driver and load centrally located on rear folded seat (max. 280 kg).

Use intermediate knob positions for other load conditions.

REFUELING

Fuel filler door

The fuel filler door lock can be opened by turning the key counterclockwise. Turn clockwise to close.

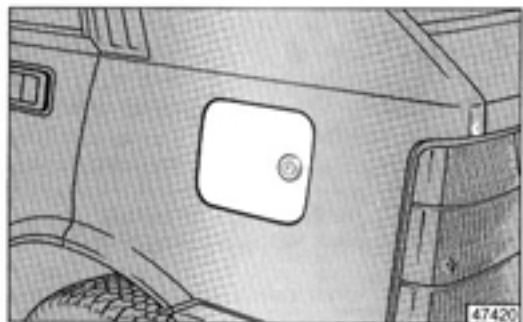

Note:

The fuel tank is pressurised to prevent fuel evaporation. The sound of air escaping you hear when opening the cap is normal.

Fuels

Use leaded or unleaded petrol with a minimum octane number of 95.

ACCESSORIES

Cigarette lighter and ashtray

Press lighter knob A fully in. After about 15 seconds it pops out ready to use.

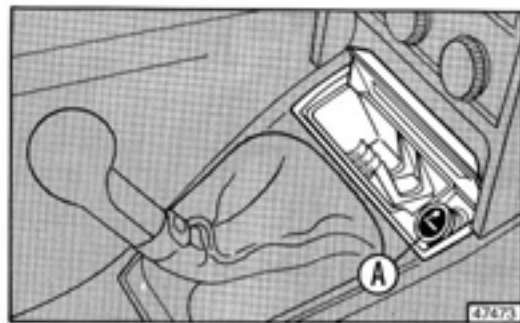

The ashtrays (rear ashtrays are located on the armrests) can be removed for cleaning.

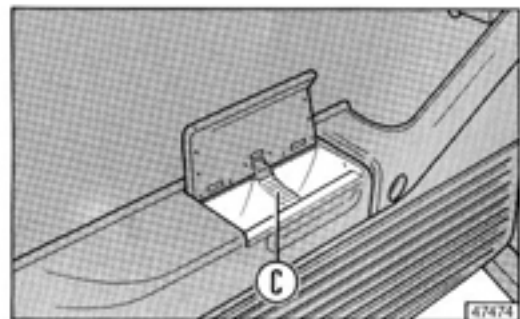

ACCESSORIES

Glove compartment

Lock/unlock the glove compartment with the key (see p.9).
Press button A to open.
A light illuminates when you open the glove compartment.

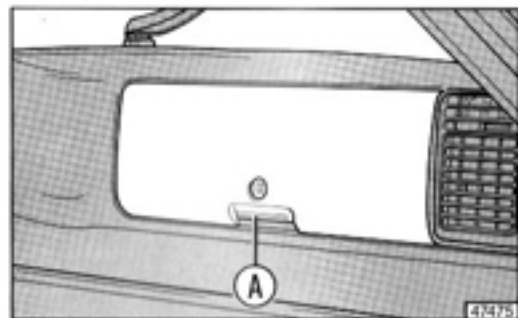

Courtesy lights

A two-position slide switch A is located next to courtesy light B. In one position the light will turn on automatically when either of the front doors is opened. Use the other position for turning on the light when the doors are closed.

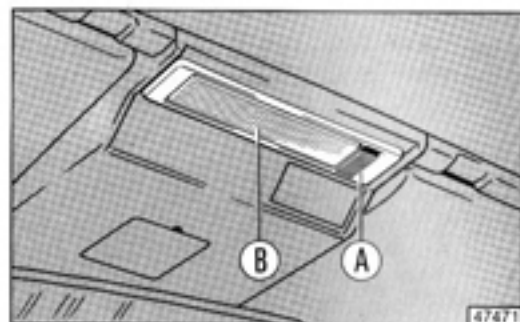

The two courtesy lights at the back of the roof panel automatically turn on when the rear doors are opened.
Press lens A to turn on a light when the doors are closed.

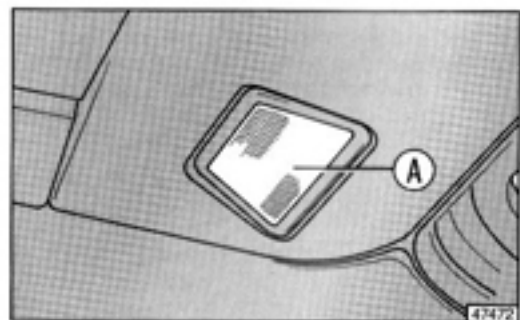

ACCESSORIES

Luggage compartment light

The luggage compartment light only illuminates when the side lights are on.

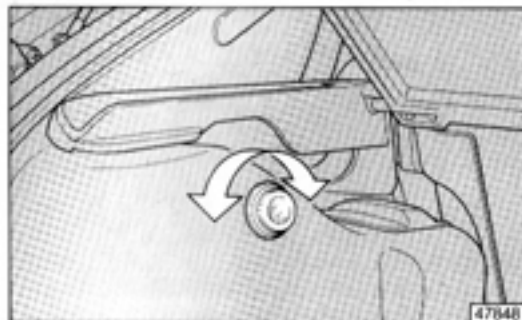

Twist the lens clockwise to turn it on, counterclockwise to turn it off.

Sun visors

The sun visors can be moved up and down or swung around to cut glare from the side windows.

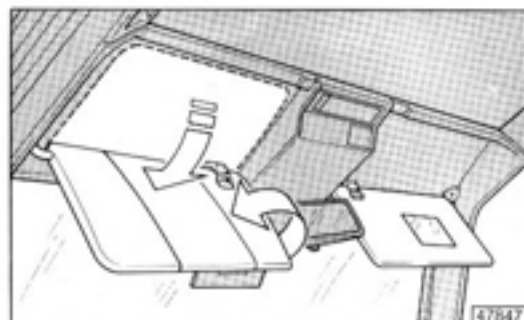

There is a document pouch on the back of the driver's sun visor and a vanity mirror on the back of the passenger's visor.

SUNROOF

Opening and closing

Press the top or bottom of rocker switch A to open or close the sunroof.

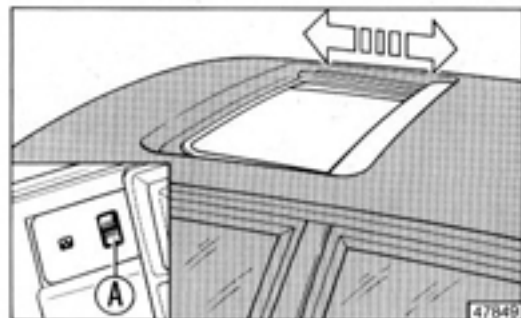

"Spoiler" position

When the sunroof is closed press the top of the rocker switch.

If the sunroof is partially open, first close it. When it stops press the top of the rocker switch again.

To lower the sunroof press the bottom of the rocker switch.

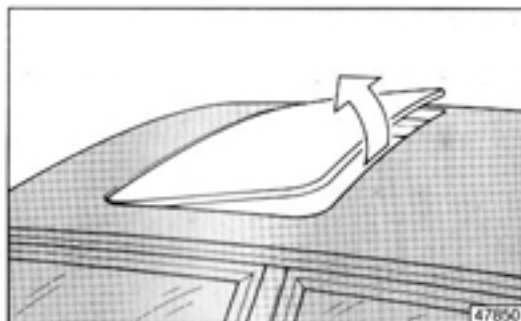

Press the top of the switch to restore the forward/rearward function.

Emergency closing

If the switch does not operate, the sunroof can be closed manually with an Allen wrench supplied with the car. Use it to turn the bushing located at the centre of the roof panel. The bushing is covered by a plastic cap that can be removed by rotating it 90°.

SOUND SYSTEM

Installation

It's easy to put an AM/FM cassette or CD player in your car because the wiring is factory-installed.

Refer to the appendix for installation schematics.

To install the radio, you'll need to remove tray A. Release the side retention springs and pull it out.

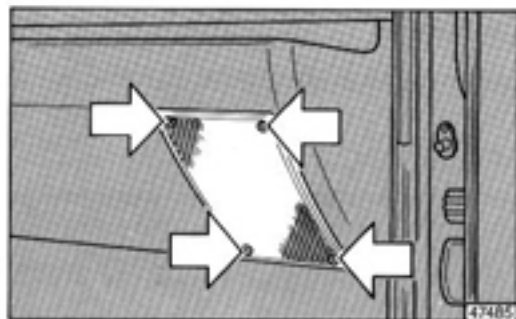
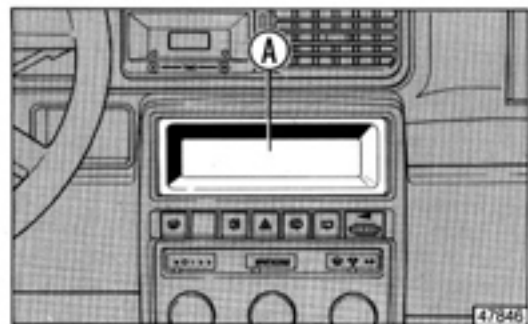

If you wish to install 4 speakers, wire four leads (2 left, 2 right) to housing A from the rear speakers.

Rear speakers may be placed on or under the shelf covering the luggage compartment.

The antenna and coaxial cable have to be installed during sound system installation.

There is a 6-pin connector for power supply and front speakers.

The front speakers should be installed in the housings located under the dashboard.

DRIVING YOUR CAR

	Page
Starting the engine	52
Gearshift Lever	53
Safety, comfort and fuel economy	53
Tow hitch	55

STARTING THE ENGINE

Cold starting

- Place the gearshift lever in neutral and depress the clutch pedal (especially in winter) to prevent the starter motor from turning the transmission shaft.
- Turn the key to AVV. Release it as soon as the engine starts.
- If your car's engine is carburetted, press the accelerator pedal fully down, then release it immediately to actuate the automatic choke. Remember to do this whenever you start the car in cold weather.

Starting a hot engine

- Press the accelerator pedal down slightly (only cars with carburettors). When the engine is very hot it may be necessary to hold down the accelerator until the engine starts. (The automatic choke does not operate when the engine is hot). The ignition switch has a non-repeating safety feature. If the engine does not start on the first attempt, turn the key to STOP before trying to start the engine again.

Fuel injected versions

The optimal fuel mixture of injected petrol engines is determined automatically under all environmental conditions.

Power devices and accessories (air conditioner, rear window defroster, windscreen wiper, etc.) do not operate when starting.

Emergency starting

If the engine does not start because the battery is dead, use another battery with the same amperage rating or slightly higher (see p. 103).

Follow the instructions on p. 68 for connecting the battery.

It is not a good idea to start the car by pushing or towing. However, if absolutely necessary, follow this procedure:

- Engage 3rd or 4th gear.
- Do not exceed 40 km/h (even when coasting downhill).
- Release the clutch pedal gradually.

Exhaust gases are toxic. Never let the engine run in an un-ventilated area.

Do not leave the key at MAR when the engine is not running.

Using the gearshift lever

Engage the gears by moving the lever according to the pattern shown in the figure (and on the top of the lever).

Wait until the car is stationary before engaging reverse. Move the lever to the right and down from the neutral position.

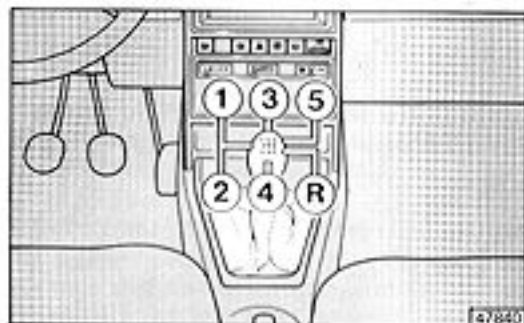

Move the gearshift lever only when the clutch pedal is fully pressed down. The area under the pedals should be kept clear of any object that might obstruct pedal travel. Always ensure the carpets lie flat and do not interfere with the pedals.

Suggestions

- Adjust your seat to a comfortable driving position, then adjust the rearview mirrors. Buckle your seat belt. Make sure all passengers have theirs buckled, too.
- Long trips, especially during summer, should be started when traffic is at a minimum. Never drive for too many hours without stopping. Make frequent rest stops. Get out of the car and stretch or take a short walk. Try to eat light, wholesome meals when travelling to improve your concentration and reflexes.
- Use the heating, ventilation and air conditioning system to provide a constant exchange of air.
- Make sure the car's headlamps are properly aligned. This is especially important for driving at night. If the headlight beam is too low, visibility will be impaired causing greater eye fatigue. On the other hand, headlights aligned too high will disturb others in front of you and drivers coming the opposite direction. The latter is usually an infraction of Motor Vehicle Code regulations.
- Never coast with the engine switched off. This is particularly dangerous because of a lack of engine braking. Furthermore, the brake system servo does not operate requiring much greater foot pressure on the brake pedal.
- After driver under conditions that heavily tax the engine, let the car idle for a couple of minutes until the coolant temperature starts to drop, then switch off the engine.

FUEL ECONOMY

Saving fuel does not necessarily mean sacrificing performance. Try the following suggestions:

- Do not race the engine while waiting at traffic lights. Try not to accelerate too rapidly when moving off.
- Double-clutching and depressing the accelerator pedal before stopping are unnecessary and may damage turbocharged engines.
- Never drive with the accelerator pedal "floored". You'll use less fuel if you accelerate gently and do not exceed two-thirds of the maximum recommended speed for each gear.



- Shift up to a higher gear whenever possible.
- Do not leave the engine running for longer than necessary.
- Fuel consumption increases when the tyres are underinflated and/or the windows are open. Low tyre pressure is also a cause of premature, uneven wear.
- Remove the roof or ski rack when you are not using it.

- When driving in heavy traffic try not to use electric devices with a high power rating (rear window defroster, maximum fan speed, etc.) to prevent an excessive drain on the battery while the alternator is charging at a lower rate.
- Take care of your car, particularly the engine, by performing "Service schedule maintenance" and "Lubrication service" operations.

TOW HITCH

General information

Your car must be fitted with an approved tow hitch in order to tow a trailer. Additionally, the car's electrical system should be modified to handle the trailer's electrical system.

You will also need to fit large rearview mirrors on the front wheel arches.

Remember that when towing a trailer you will be unable to drive on grades as steep as those indicated in the "Gradeability" table.

When driving downhill use a lower gear instead of braking repeatedly.

The load exerted by the trailer and the weight of the hitch have to be subtracted from the car's maximum permissible payload to determine the maximum load.

The term "maximum towable weight" indicates the weight of a fully laden trailer including luggage and accessories.

Ensure the trailer's overall weight is under the maximum permissible indicated on the car's registration papers.

Installing a tow hitch

You are responsible for bolting the tow hitch to the car's body according to the diagram on p. 57.

The electrical connector socket should be attached to a bracket bolted onto the car's body near the hitch.

Use either of the following couplings:

- "CUNA 501" ball coupling.
(CUNA NC 138-30 standard).
- "CUNA 501" socket coupling.
(CUNA NC 438-15 standard).

Use a 7-pin 12V connector for the trailer's electrical system (CUNA NC 165-30 standard).

Replace the direction indicator flasher unit with another able to handle twice the load (suitable for three 21 W bulbs). The trailer's ground should be connected to the car's (via the 7-pin connector) using a cable having a 2.5-mm² cross section.

In addition to the required wiring illustrated in the schematic, only a power supply cable for an electrical trailer braking system and a trailer courtesy light (not more than 15 W) may be connected.

The electrical braking system must be directly connected to the car's battery with a cable having a cross section greater than 2.5 mm².

Additional tow hitch installation information is provided in the appendix of this handbook.

TOW HITCH

Brakes

Under no circumstances may the car's braking system be modified to control the trailer's brakes. The trailer's braking system must be entirely independent of the car's hydraulic system.

Note: If your car has a "check system", the power supply connector for the taillights, stop lights and trailer's number plate lights must be attached after the fuses and before the dropping resistors contained in the check unit that monitors the car's light bulbs.

Legend for schematic

- 1 - Electromagnetic braking system connection.
- 2 - Stop light switch connection.
- 3 - Rear fog-guard light switch.
- 4 - Rear fog-guard light connection at fuse box.
- 5 - Direction indicator power supply connection.
- 6 - Taillight power supply connection.
- 7 - 7-pin socket.
- 8 - Ground for 7-pin socket.

Black lines : Factory wiring.

Red lines : Wiring to be performed by the installer.

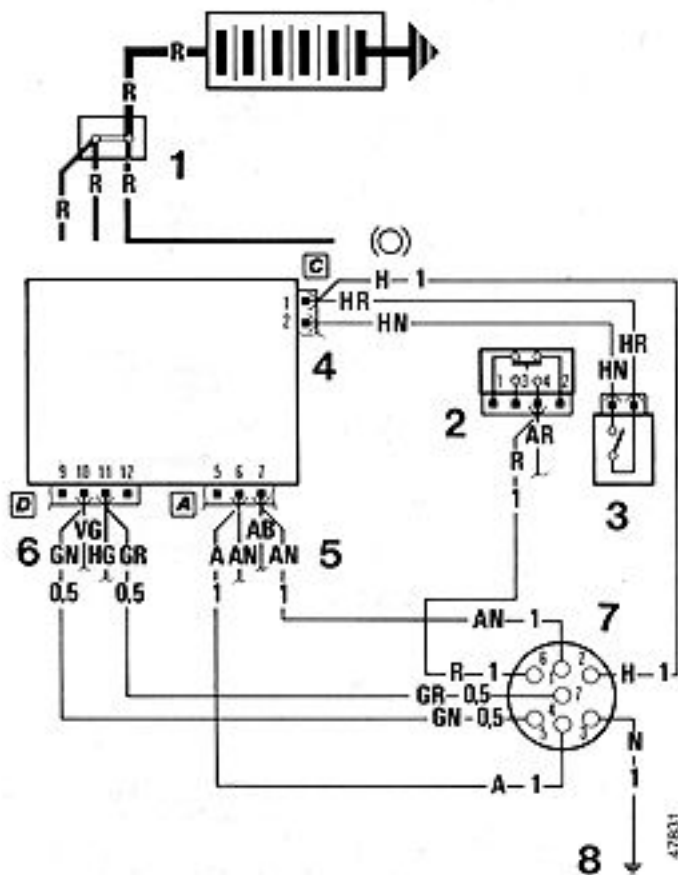

TOW HITCH

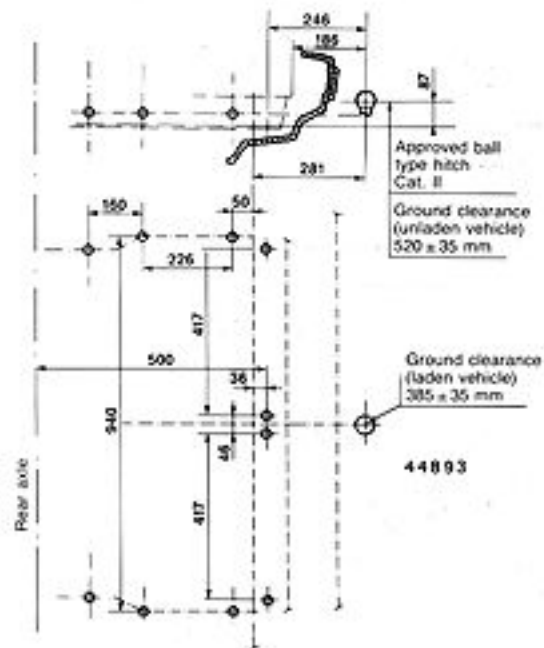

NB - The installer is required to attach a clearly legible plate at the same height as the hitch. The plate should be made of an appropriate material and have the following stamped on it:

MAXIMUM LOAD AT THE COUPLING: 70 kg

The drawing shows the points where the tow hitch hardware must be bolted to the car's body.

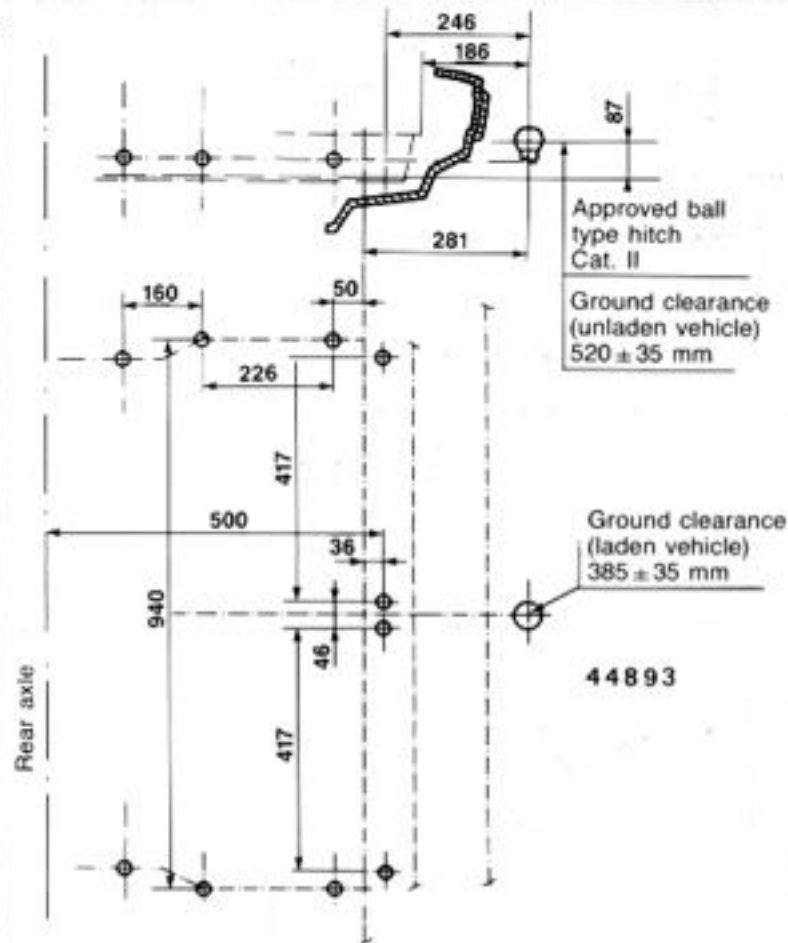

WHAT TO DO IF...

	Page
... a tyre is punctured	60
... an interior light burns out	62
... an exterior light burns out	63
... a fuse blows	66
... the battery is dead	68
... the car has to be towed	69
... the car has to be jacked up	69

...A TYRE IS PUNCTURED

Replacing a wheel

Park the car on firm, level ground. Set the handbrake and engage 1st gear or reverse. Use wedges or rocks to keep the car from moving. Lift the luggage compartment mat and attach it to the bottom of the shelf as shown in the figure to reach the spare.

Remove the jack and tools from the compartment located on the right side of the luggage compartment.

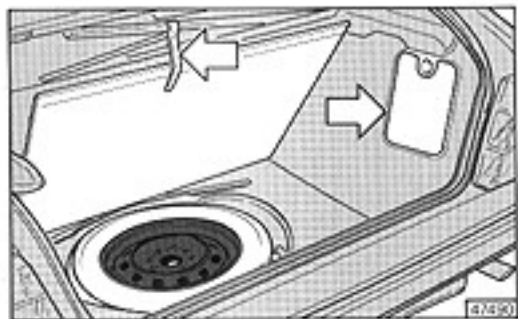

Loosen the wheel bolts about one turn using handle A and socket B with ring nut D. Place the six-point end of the socket on the wheel bolt and the other on handle A. Handle A can be used to loosen or tighten the wheel bolts depending on which side is inserted in socket B.

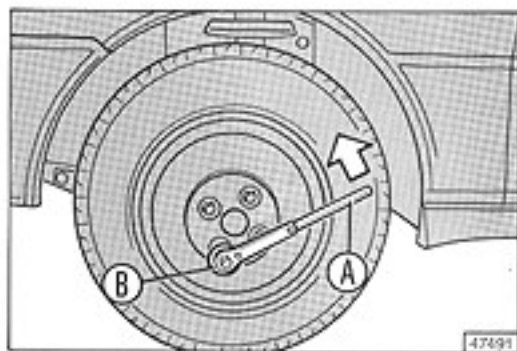

Now, insert socket B on the jack and place it under red reference point C (see figure). Turn the ring until the jack is against the car.

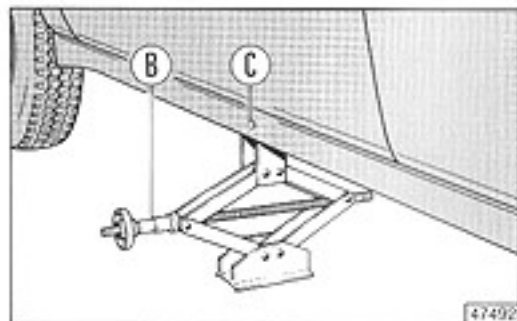

Place handle A on socket B.

...A TYRE IS PUNCTURED

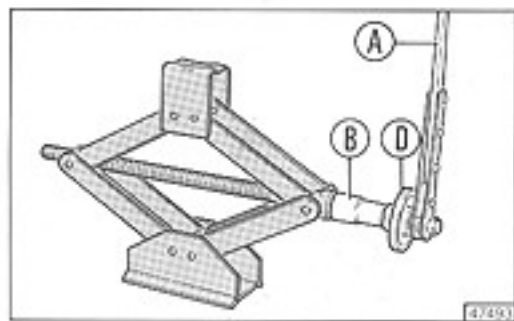

Turn handle A back and forth until the wheel is raised off the ground.

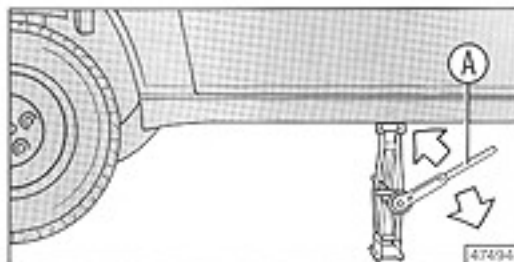

Unscrew the four wheel bolts you previously loosened and remove the wheel. Put the spare on the hub ensuring the peg fits in one of holes on the wheel.

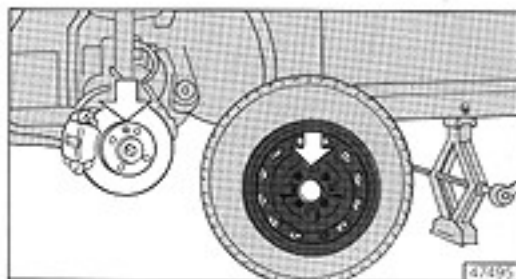

Screw in the four wheel bolts.

Lower the car and remove the jack.

Tighten the bolts in a uniform, criss-cross fashion. Check wheel bolt tightness again after driving about 100 km.

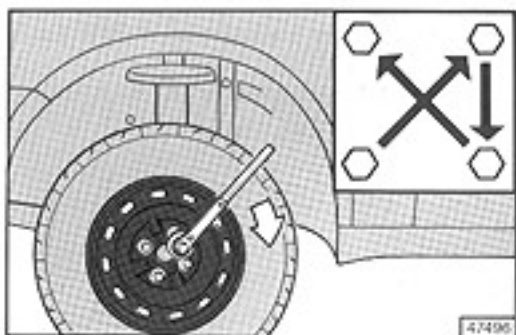

...A TYRE IS PUNCTURED

Important

Use the jack for wheel changing only. Under no circumstances should it be used to raise the car for underbody repairs.

If you wish to use rims different from those supplied as standard equipment, ask your LANCIA dealer for advice. Only approved spare parts are guaranteed to fit and work properly.

The small space-saver spare should only be used to drive to a garage for repairs. **Never exceed 80 km/h.**

Inflation pressure: 2.8 bar.

The spare can be used for a maximum of 3000 km.

Never use two space-saver spares at the same time.

...AN INTERIOR LIGHT BURNS OUT

General information

- If a light does not illuminate, check the fuse protecting the circuit before replacing the bulb.
- Replace bulbs that have burned out with bulbs of the same type and wattage.
- **Always handle halogen bulbs by the metal base. If you touch the glass the bulb's life will be considerably shortened.**

If you accidentally touch a bulb, clean it with a rag moistened with alcohol and then let it dry completely.

Luggage compartment light

Remove the press-fit bulb holder by releasing spring clips A. Press and move contact C towards slot B. Pull the bulb holder out diagonally from the side opposite the slot and remove the 5W bulb.

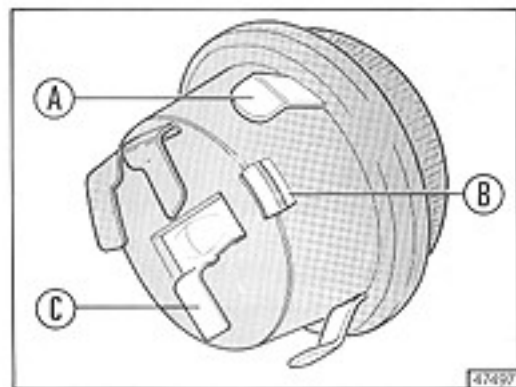

Glove compartment light

Remove the lens and pull out the bulb holder. Remove and replace the press-fit 5W bulb.

Courtesy lights

Pry off the courtesy light lens using a screwdriver.

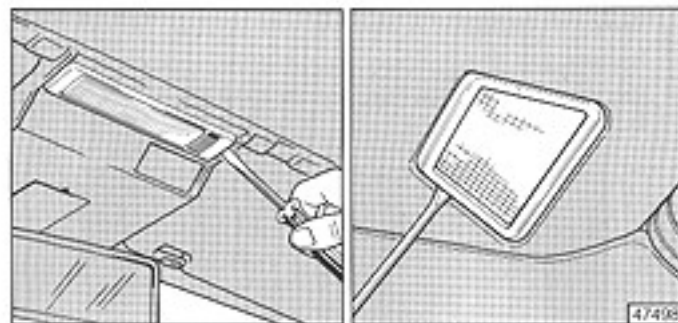

Remove the unit and replace the 5W bulb.

Headlamps

Always replace bulbs using new bulbs of the same type and wattage.

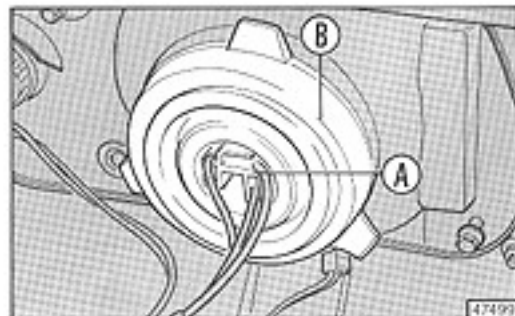

...AN EXTERIOR LIGHT BURNS OUT

- Remove connector A and pull off boot B.
- Release spring clip C.
- Replace 65/55W bulb D holding the new bulb only by the base.

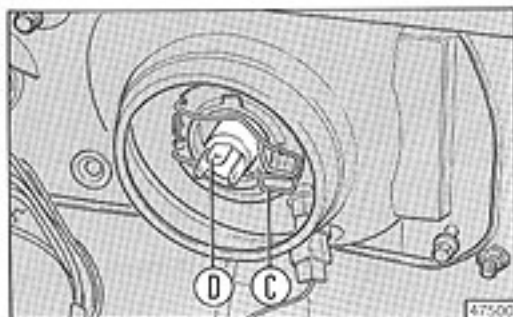

Front side lights



Remove press-fit bulb holder E. Remove and replace the 5W bayonet-base bulb.

Front direction indicators

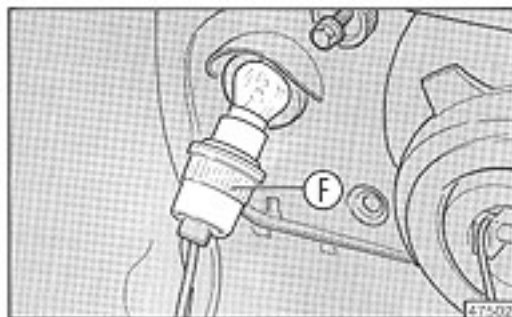

Pull out bayonet-mount bulb holder F. Remove and replace the 21W bayonet-base bulb.

Direction indicator repeaters

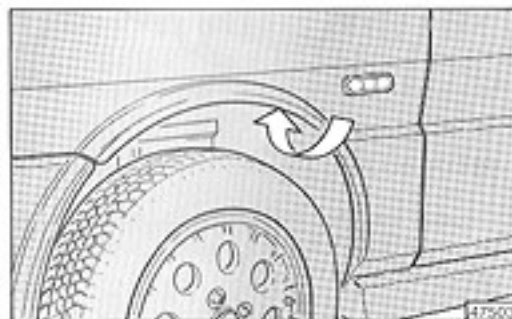

Swing the wheel arch liner aside and remove the press-fit bulb holder. Remove and replace the 4W bulb.

...AN EXTERIOR LIGHT BURNS OUT

Taillights

Unscrew the four screws **A** and remove the lens.

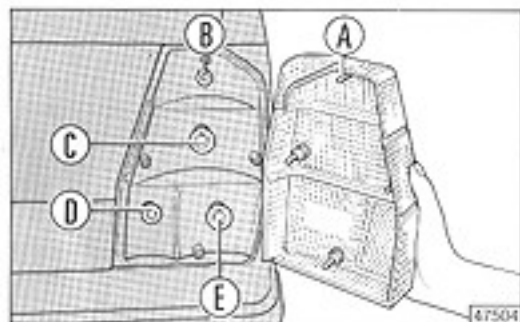

Remove the bayonet-base bulbs needing replacement.

- B = Stop light bulb.
- C = Direction indicator bulb.
- D = Taillight bulb.
- E = Fog-guard bulb.

Back-up lights

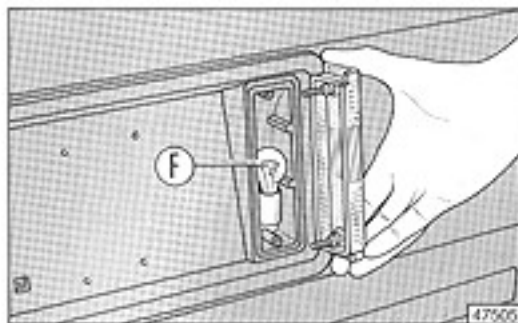

Unscrew the two screws holding the lens in place. Remove and replace 21W bayonet-base bulb **F**.

Number plate lights

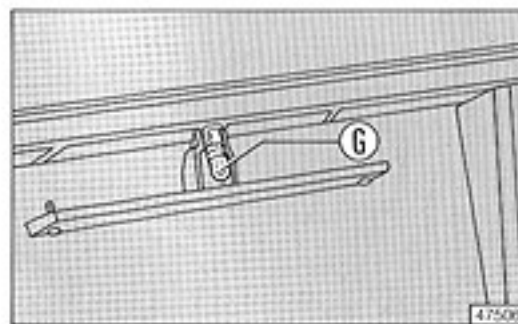

Unscrew the two screws holding the lens in place. Remove and replace 4W bayonet-base bulb **G**.

...A FUSE BLOWS

There are 14 fuses in the fuse box located to the left of the steering column. Turn knob B to open the fuse box cover.

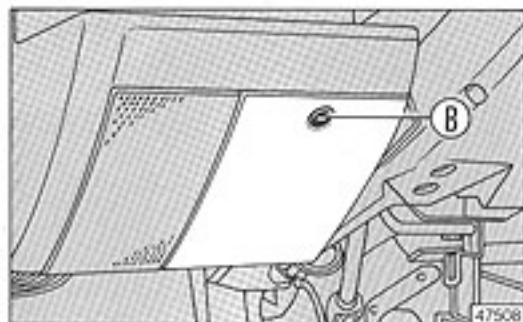

The amperage rating of each fuse is stamped on it. A symbol representing the main electrical device protected appears above the fuse.

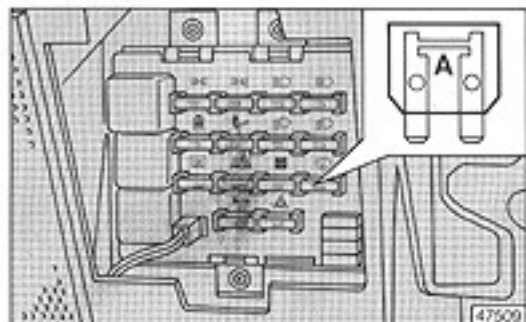

To check a fuse remove it and make sure the element is intact. If not, replace it with another fuse having the same amperage rating.

Fuses

SERVIZI
SERVICES



10 A Back-up lights, instrument panel power supply, direction indicators, stop lights, digital clock, check system.



20 A Windscreen wiper and intermittent control, windscreen washer pump, rear window wiper, rear window washer pump.



7.5 A Left front side light, right taillight, number plate light, cigarette lighter night light.



7.5 A Right front side light, left taillight, side light panel indicator, clock light, glove compartment light, luggage compartment light, instrument panel and check system dimmer.



10 A Left low beam headlamp and panel indicator, fog-guard lights and panel indicator.



10 A Right low beam headlamp.

10 A Left high beam headlamp and panel indicator.



10 A Right high beam headlamp.



25 A Radiator fan.



20 A Heater fan.



20 A Rear window defroster and panel indicator.



10 A Cigarette lighter, radio, courtesy lights, digital clock, ignition key light.



10 A Hazard warning lights and panel indicator.



20 A Horn.

Note: The ignition, starter motor, oil pressure warning light and rear window defroster relays are not protected by fuses. Three other fuses are located under the shift lever boot. One 15A fuse protects the power lock system (if fitted) and two 25A fuses protect the power windows (if fitted).

On some versions, a 20A fuse protects the manifold idle resistor, automatic choke resistor and fuel pump cutoff. Other versions have a 15A fuse in the air intake duct that protects the injectors, fuel pump, and air intake and overboost solenoids.

...THE BATTERY IS DEAD

Jump starting

If the battery has lost its charge, start the engine using another battery with an amperage rating equal to or greater than your car's battery (see p. 103). Follow this procedure:

- Connect the two positive battery posts with a jumper cable.
- Connect one clamp of the second jumper cable to the negative terminal of the other car's battery and the other side to your car's ground bracket.

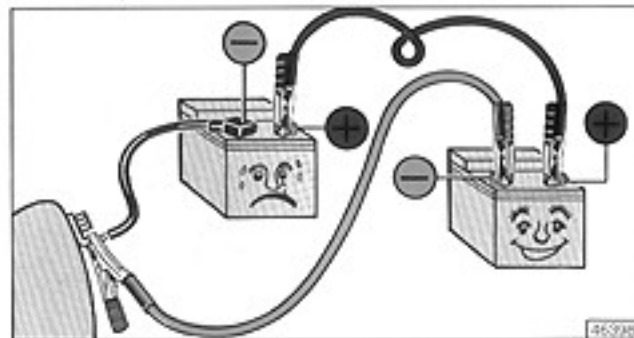

- When the engine starts remove the jumper cables starting with clamp connected to the ground bracket.

Never use a battery charger to start the car.

Recharging

Carefully follow this procedure to recharge the battery.

- Disconnect both cables from the battery.
- Connect the battery charger's clamps to the battery. Now, turn the charger on.
- When charging is completed, turn off the charger before removing it from the battery.
- Apply petroleum jelly or another suitable compound to the terminal posts before reconnecting the cables.

Refer to the MAINTENANCE chapter for further information regarding the battery.

IMPORTANT: The battery electrolyte is toxic and corrosive. Avoid contact with skin and eyes.

Recharging must always be done in a well-ventilated area. Never expose the battery to an open flame or sparks.

Charge the battery with a trickle charger (low amperage for at least 24 hours).

Always disconnect the battery's negative cable before servicing the car's electrical system.

Tow eyelets

Attach a tow cable to the eyelets illustrated in the figures.

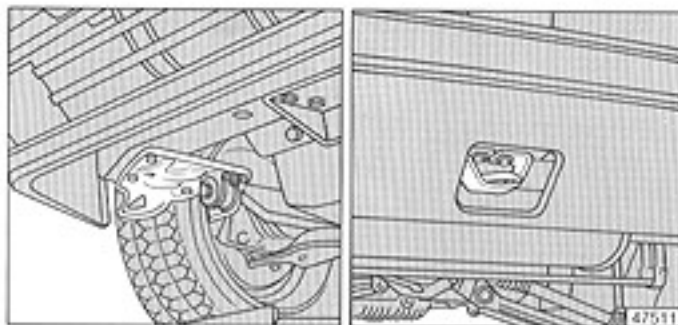

Important

- Respect all vehicle code regulations regarding towing.
- Always leave the ignition key at MAR to prevent the steering wheel from locking. If the electrical system has not been damaged, the brake and indicator lights may also be used.
- Braking when the engine is not running requires additional foot pressure on the brake pedal because the brake servo unit is inoperative.

Using the car's jack

Refer to p. 60 for information regarding wheel changing.

The car's jack should only be used for replacing a wheel. Never use it to raise the car for underbody repairs.

Using a hydraulic jack

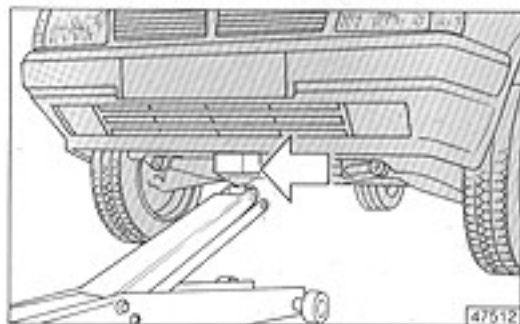

The jack should be placed **only** under the point indicated in the figure. Place a 15x15 cm board between the jack and the car.

...THE CAR HAS TO BE JACKED UP

When jacking up the car from the rear with a hydraulic shop jack, you **must** place an appropriate spacer (see figure) between the tow bracket and the jack.

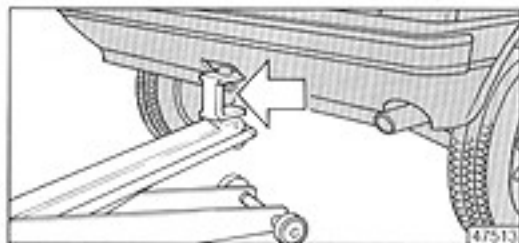

MAINTENANCE AND SERVICING

	Page
Maintenance	72
- Free service coupon	72
- Service schedule	73
- Lubrication servicing	75
- Driving under adverse conditions	75
- Additional checks	76
Checking fluid levels	77
Air cleaner	81
Oil filter	81
Fuel filter	81
Electrical and electronic devices	82
Carburettor	84
Alternator belt	84
Handbrake	85
Clutch	85
Tyres	86
Heating system filter	88
Windscreen and rear window wipers	88

Free service coupon

Every new car comes with a **free service coupon** which must be used after driving 1000-1500 km. The service operations listed below (and in the Service Handbook) are required by the terms of the warranty.

The following are checked and adjusted if necessary:

- Engine idle.
- Alternator/water pump belt.
- Clutch pedal travel.
- Handbrake lever travel.
- Tyre wear.
- Headlight beam alignment.
- Exhaust pipe bolts.
- Brake proportioning valve boot.
- Brake and steering/power steering systems (check for leaks).

The following fluid levels are checked and topped up:

- Power steering and brake fluid, coolant, windscreen and rear window washer fluid.

The following is changed:

- Engine oil.

Final inspection

NB: The following are checked in cars with air conditioning:

- Compressor drive belt tension.
- Pulley and compressor bolts.
- Operation and cooling efficiency.

Service schedule

Regular maintenance ensures your car will remain in excellent condition for many years.

LANCIA has elaborated a service schedule which is listed on the four coupons (charged to owner) included with the warranty and on the next page.

If any additional servicing is found to be necessary when performing service schedule maintenance, your approval will be requested before proceeding.

All members of the LANCIA Service Organisation perform service schedule maintenance.

Minor problems such as fluid leaks should be immediately reported to a Service Centre. Do not wait until the next service coupon. Maintenance should be performed at least once a year, even if you have driven fewer kilometers than indicated in the tables.

If your car has air conditioning, check it every two weeks. Turn on the air conditioner and let it operate for a couple of minutes (even during winter).

Switch on the air conditioner only after the engine has warmed up.

Before summer (and every time the system is serviced) have the Freon and compressor oil levels checked. Top up whenever necessary.

MAINTENANCE

Service schedule maintenance operations	km x 1000			
	20	40	60	80
Inspect toothed timing belt		+		+
Inspect tyres and check pressure	+	+	+	+
Verify disc pad wear	+	+	+	+
Check rear brake drum linings		+		+
Inspect lines and pipes (exhaust, fuel and brakes)	+	+	+	+
Check condition of rubber parts (hoses, boots, gaiters)	+	+	+	+
Inspect drive belts, adjust tension when necessary	+	+	+	+
Check/adjust clutch pedal travel or height	+	+	+	+
Check/adjust handbrake lever travel	+	+	+	+
Check/align headlight beams	+	+	+	+
Replace air cleaner element	+	+	+	+
Check crankcase ventilation				+
Check/adjust valve clearances	+		+	
Verify radiator fan operation; check/adjust idle speed	+	+	+	+
Verify electrical devices operate efficiently (lighting, indicator and warning lights)	+	+	+	+
Top up fluid levels (coolant, brake and power steering fluid, windscreen washer fluid, etc.)	+	+	+	+
Lubricate door hinges and locks	+	+	+	+
Check exhaust emissions	+	+	+	+
Check transaxle oil level	+	+	+	+
Replace fuel filter	+	+	+	+
Replace spark plugs; check cables and distributor cap	+	+	+	+
Analyze electronic ignition/injection on versions with diagnostic plug (IAW, Microplex, SPI)		+		+
Check Breakerless ignition advance		+		+

Lubrication servicing

Recommended oils and change intervals are given in the table on p. 107.

Driving under adverse conditions

Adverse driving conditions include areas with high dust levels, mountain roads, city driving, towing a trailer, or high-speed highway driving.

Under these conditions, "lubrication servicing" should be performed more frequently than indicated. The following parts are particularly subject to wear. They should be checked more often.

- Spark plugs and air cleaner element.
- Front disc brake pads.
- Tyres.

Additional checks

The following checks should be carried out in addition to those described in the Service Schedule.

Every 500 km or before a long trip

- Engine oil level.
- Coolant level.
- Brake fluid level.
- Tyre pressure.

Change or replace the following:

Every 10,000 km

- Spark plugs (turbo versions).

Every 60,000 km or 2 years

- Coolant.

Every 100,000 km

- Toothed timing belt.

Every 120,000 km

- Transaxle oil.

Every year

- Brake fluid.

We highly recommend the use of Original Lancia Spare Parts. Every original part meets the same high standard of quality as factory-installed parts.

Use FIAT oils. They've been lubricating your car's engine since the first time it started.

CHECKING FLUID LEVELS

Engine oil

Check the oil when the car is on level ground. Wait about 10 minutes after switching off the engine.

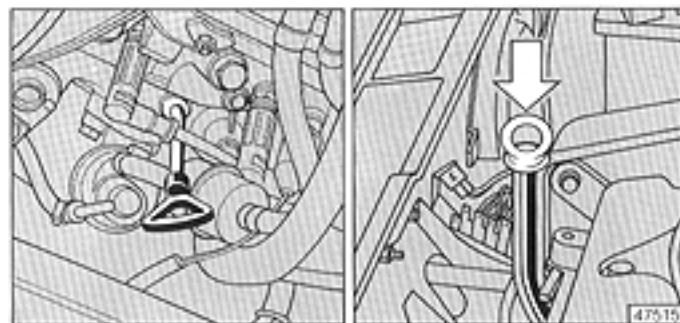

1500 cc engine

1600 cc engine

Whenever you top up or change the oil let the engine run for a few seconds, wait a couple of minutes and then check the level again.

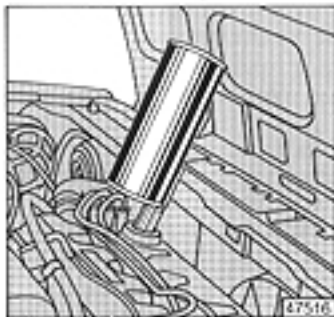

Verify that the oil level is between the MIN and MAX marks on the dipstick. When the level is under the MIN level, add oil through the oil filler hole until reaching the MAX mark.

Never fill above the MAX mark.

The oil volume between the MIN and MAX marks corresponds to about 1 litre.

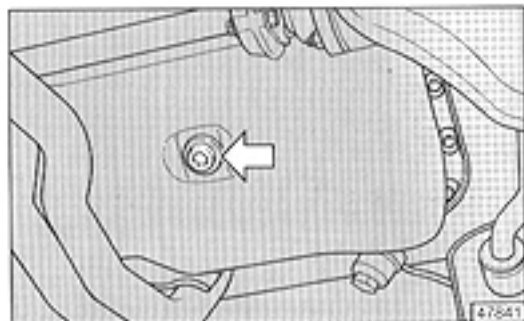

Remove the sump plug to drain the oil. Wait about 10 minutes before replacing the plug. Draining the oil will be easier if you remove the oil filler cap and dipstick.

Drain the oil only when the engine is hot.

If you mainly drive in dusty or urban areas, change the oil and cartridge filter more frequently than suggested in this handbook.

CHECKING FLUID LEVELS

Transaxle oil

When the car is parked on level ground the transaxle oil level should reach the lower edge of filler hole A.

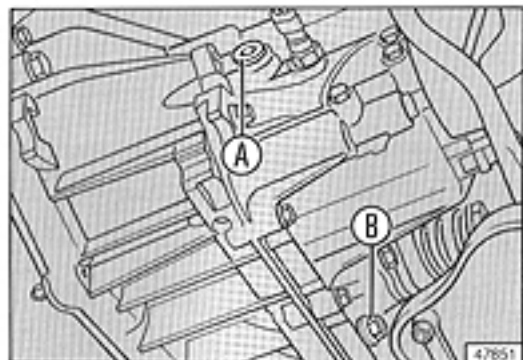

To change the oil, unscrew plug B. Let the oil drain for about 10 minutes and then replace the plug.

Disposing of used oil

The oil drained from your car should be disposed of in compliance with current regulations.

Power steering fluid

Remove the dipstick incorporated in cap B to check the power steering fluid level, which should be at the maximum mark when the engine is running.

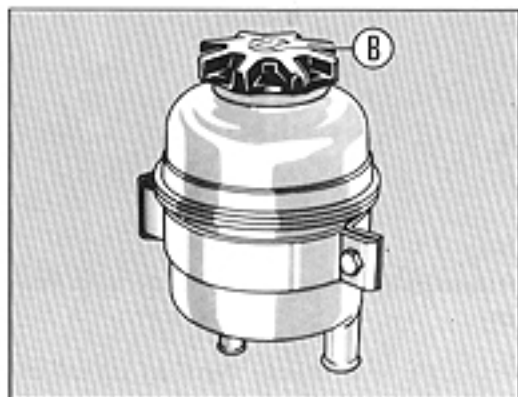

45414

When the fluid is hot the level may be higher than the maximum mark on the reservoir.

CHECKING FLUID LEVELS

Brake fluid

Visually check the fluid level once a week without removing the cap.

Periodically check the operation of the fluid level panel warning light. When you press the reservoir cap (key at MAR) the light should turn on.



Top up only with **DOT 4** brake fluids. **Tutela DOT 4**-used during factory assembly of the brake system-is recommended.

Never use fluids with different specifications. They can cause permanent damage to the brake system seals.

Because brake fluid is corrosive, never let it come in contact with the car's body paint. Rinse off immediately with water if fluid drips onto the car.

Coolant

The coolant level should only be checked and topped up when the engine is cold.

The level should be a couple of millimetres above the expansion tank mark when the heater valve is open.

When the engine is hot never remove the expansion tank cap to avoid getting scalded.

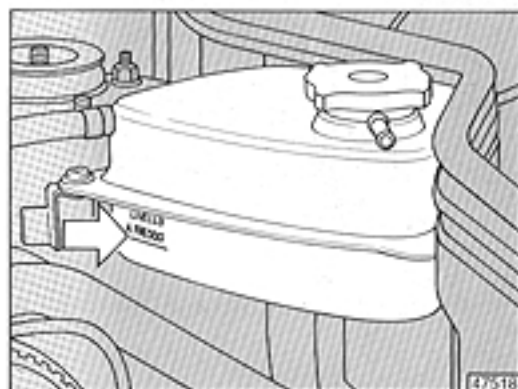

Use a 50-50 mixture of of antifreeze and distilled water for topping up. The recommended coolant is **Tutela FIAT Paraflo[®]**.

Draining the coolant:

- Open the heater valve by turning knob **B** fully clockwise (see p. 26).

CHECKING FLUID LEVELS

- Remove the expansion tank cap.
- Pull off the hose connecting the radiator with the water pump on the radiator side.

Refilling the cooling system:

- Open the heater valve by turning knob **B** fully clockwise (see p. 26).
- Reconnect the radiator hose.
- Slowly pour the coolant mixture into the expansion tank through the filler hole until the level is a couple of millimetres above the mark.
- Replace the expansion tank cap.
- Start the engine. Let it idle until you no longer see air bubbles in the coolant.
- Let the engine cool off, then top up the coolant level.

When the engine is hot

See the chapter regarding the bonnet (p.43) for information regarding the radiator fan.

Windscreen and rear window washer fluid

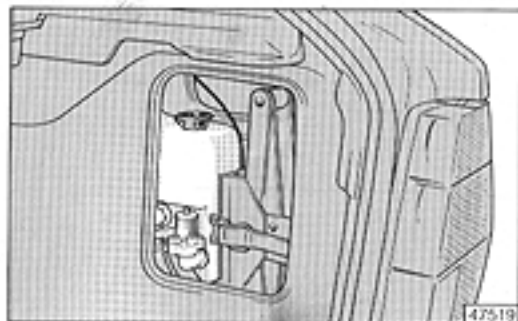

Frequently check the level in the washer reservoir (located in the same compartment as the jack on the right side of the luggage compartment).

Remove the plug and top up with a mixture of water and **Autofá n. 9 DP I** (see note on p.107).

Ensure the plastic tubing is not clogged. Clean the washer nozzles with a pin if necessary.

AIR CLEANER

Cleaning or replacing the filter element

Release clips **A** to remove the housing cover. Remove and replace the filter element.

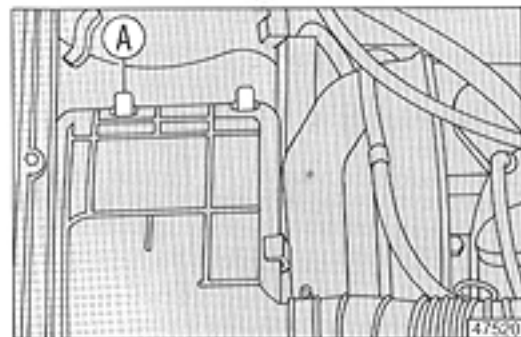

Note: A dirty filter causes an increase in exhaust emissions and smoke opacity, as well as poorer engine performance.

High emission levels are in violation of clean air standards.

OIL FILTER FUEL FILTER

Replacing the oil filter

Replace the filter every time you change the oil.

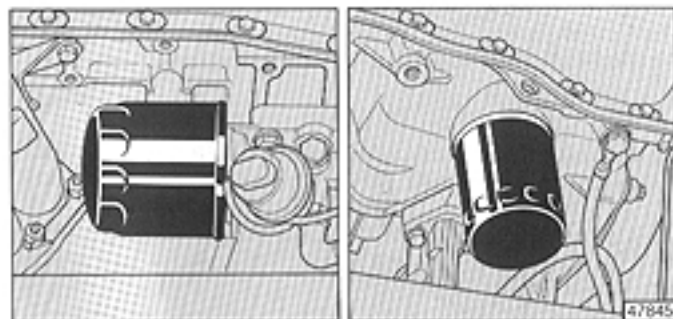

1500 cc engine

1600 cc engine

Lubricate the seal of the new filter before screwing it onto the engine block.

Replacing the fuel filter

Replace the fuel filter every 20,000 km.
This operation is performed by a Lancia Service Centre as part of service schedule maintenance.

Battery

General information

The battery is maintenance-free, and does not need to be topped up with distilled water.

The electrolyte level (car on level ground) should be between the the MIN and MAX marks on the battery.

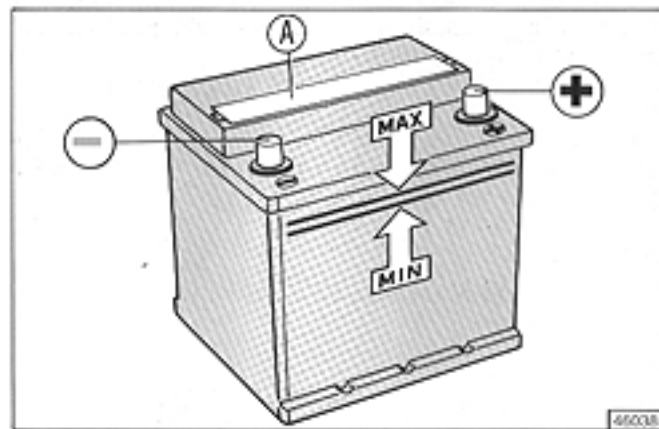

If absolutely necessary, the battery can be topped up by removing cap A. Add distilled water until the level reaches the MAX mark. Never overfill the battery.

Important: The electrolyte solution in the battery is corrosive and toxic. Avoid contact with skin and eyes.

Lead batteries should be disposed of in compliance with local regulations.

Warnings

The battery will hold its charge and last longer if you follow these suggestions:

- When you leave the car in a garage insure the doors and glove compartment are closed to prevent the interior lights from remaining on. Remember to turn off the map light.
- Do not leave electrical accessories on for a long time when the engine is not running (radio, hazard warning lights, side/taillights, etc.).
- If you install other accessories (remote controls, vehicle alarm system, radio with memory features) ask your Lancia dealer for advice regarding suitable devices.
- The standby power consumption of the aftermarket devices installed should not exceed 20 mA.

If the battery loses its charge, refer to p. 58 for further information.

Electronic control units

The car's ignition, injection and other control units do not generally need to be serviced.

However, you should take a number of precautions during diagnostic procedures, servicing or emergency starting.

- Never disconnect the battery when the engine is running.
- Disconnect the battery from the car's electrical system when charging it.
- Do not use a battery charger to start the engine. Always use another battery.
- Ensure the battery is properly connected to the car's electrical system. Check the polarity is correct and all cables and clamps are in good condition.
- Never disconnect or connect control units with the ignition key is at MAR.
- Never check battery polarity by sparking.
- Disconnect the control units when arc welding body panels. Remove the control units when temperatures could exceed 80 °C (body painting).

Warning

It may be dangerous to make improper connections or modifications to the wiring harnesses of some of the car's systems (ignition, injection, etc.).

Improper installation of sound systems and/or electronic vehicle alarm systems can create interference with the car's electronic control units.

Spark plugs

The condition of the spark plugs is an important factor in limiting exhaust emissions. Poor plug condition can also affect engine life and performance.

An improper air/fuel mixture will eventually cause plug deposits and shorten their life.

If the engine is not operating properly, have the spark plugs checked at a LANCIA Service Centre or by a skilled mechanic.

The spark plugs can often provide useful information when performing engine troubleshooting procedures.



Always use recommended spark plugs. Plugs with the wrong heat ratio will cause poor engine performance.

CARBURETTOR - ALTERNATOR BELT

Adjusting engine idle speed (1500 cc engine)

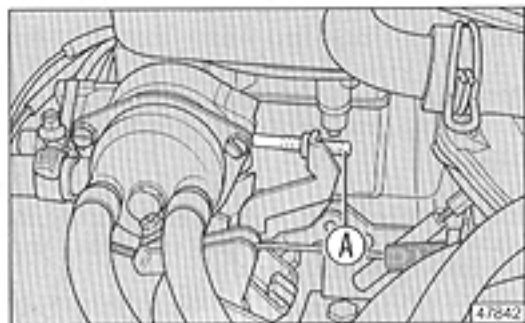

Turn screw **A** to adjust the carburettor throttle valve if the idle speed is not correct.

If this does not solve the problem, take your car to a LANCIA Service Centre for a thorough fuel supply system check. The Centre will check the idle mixture by determining the CO (carbon monoxide) level in the exhaust.

For other engines, have all procedures performed at a Service Centre as expertise and sophisticated equipment are required.

Adjusting belt tension

The alternator belt should never show signs of wear (cracks

or fraying), and should be properly tensioned to prevent slippage.

Although belt tensioning should be performed with specific equipment at a LANCIA Service Centre, you can use the following procedure in an emergency.

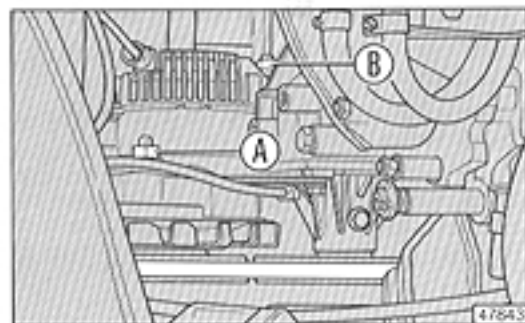

- Loosen tensioning nut **A**.
- Loosen alternator nut **B**.
- Pull the alternator outwards and tighten the nuts (first **A** then **B**).

Do not overtighten the belt to prevent premature bearing wear. The belt is properly tightened if it moves downwards only about 1 cm when you press it with your thumb.

Note Depending on the version, the alternator and bolts shown here may have a slightly different location, but the procedure is the same.

Adjusting the handbrake

Follow this procedure to adjust handbrake travel:

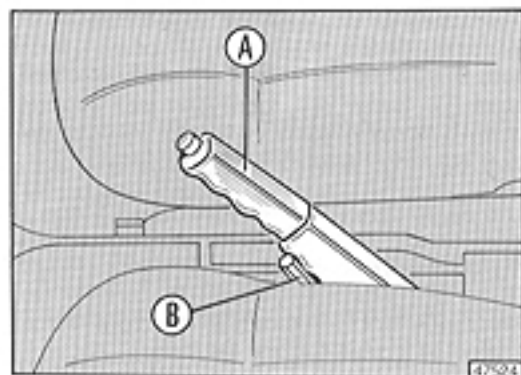

- Pull lever **A** up from the released position.
- Turn nut **B** until the cable is taut.
- Verify that the car does not move when handbrake lever **A** is pulled up three or four clicks.

Adjusting pedal height

The mechanical clutch is self-adjusting and has no pedal free travel.

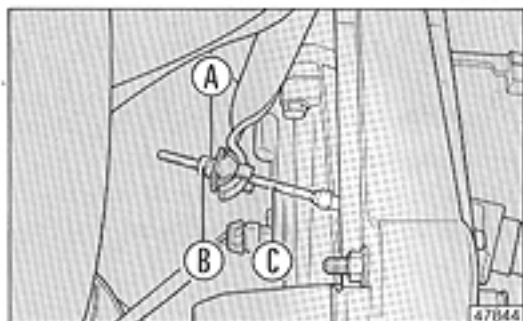

If pedal height adjustment is required, turn nut **A** on clutch cable **C**. Tighten nut **A** to raise the pedal or loosen it to lower the pedal.

Tighten locknut **B** when the pedal is at the right height.

TYRES

Pressure and tyre wear

Make sure the tyres are always inflated to the correct pressure. This will increase their life, improve handling and guarantee driving safety.

Verify tyre pressures (including the spare) every two weeks and before taking long trips using a pressure gauge. Tyre inflation pressures (cold) are given on the table on the inside front cover.

Incorrect tyre pressure causes irregular wear.

A - Correct pressure: Tyre wears evenly.

B - Underinflated tyre: Shoulder tread wear.

C - Overinflated tyre: Centre tread wear.

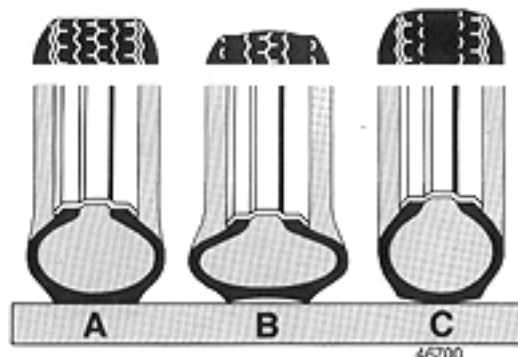

Notes

Always check tyres when they are cold.

Tyres heat when driving causing an increase in pressure. If you have to check the pressure of a hot tyre, remember to add about 0.3 bar to the cold-tyre value indicated.

Driving with underinflated tyres will lead to more rapid heating, often causing permanent damage.

The tread depth should not be less than 1.5 mm*. The less tread present, the lower the road traction. Always drive carefully on wet roads.

Tread wear indicators are moulded into some tyres. As soon as they become visible replace the tyres.

Inspect the tyres for irregular tread wear or sidewall cuts. If not wearing evenly, have the tyres checked at a LANCIA Service Centre.

* After January 1, 1992 minimum tread depth is 1.6 mm (EEC directive 89/459).

Important

Impact against the kerb, potholes or other objects, as well as frequent driving on poorly surfaced roads, may damage the tyres.

If a blowout occurs, stop as soon as possible to change the tyre. Driving on a flat tyre will damage it.

Always remove the tyre from the wheel to inspect for damage.

Tyres can age even when they are not used. Tread or sidewall cracking and distension are signs of age. Have these tyres checked by an expert.

If the tyres have been on the car for over 6 years have them carefully checked. Also inspect the condition of the spare. Replace it as soon as possible if it is not in excellent condition.

Never use cheap, recapped tyres.

Never use inner tubes in tubeless tyres.

Always replace the inflation valve when changing a tyre.

Rotate the tyres (exchanging the front tyre with the rear one on the same side of the car) every 10,000-15,000 km to ensure even wear.

Never rotate the tyres in a criss-cross fashion.

Snow chains

The use of snow chains is governed by local regulations. Use snow chains only on the front wheels of front-wheel drive cars.

Always recheck chain tension after driving about 30 metres. Drive at moderate speeds when using chains to avoid damaging the tyres. Do not drive on snow-free roads.

Always use low-profile chains. The maximum height of the chains should not exceed 12 millimetres.

HEATING SYSTEM FILTER WINDSCREEN/REAR WINDOW WIPERS

Heating system filter (GT i.e. and HF turbo)

Remove screws **A** to reach the filter. Move the filter unit to the right, lift and replace it.

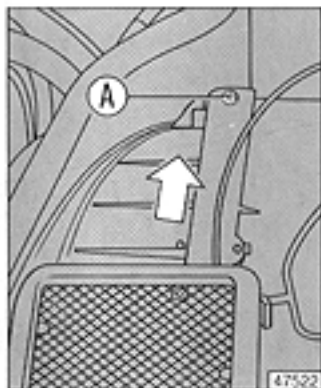

Windscreen and rear window wipers

If the wiper blades are not operating efficiently, try cleaning them with **Autofan 9 DP1** fluid or alcohol. If cleaning them does not help, replace the blades.

Replacing the blades

Press tab **C** downwards on wiper arm **D**.
When the spring tab releases from the wiper arm's curved tip, slide it off arm **D** through the slot.

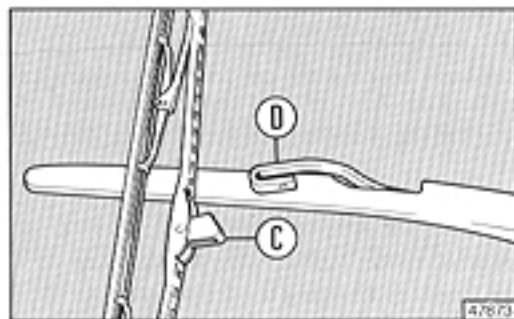

Note After washing your car in a car wash, ensure the blades are positioned above the lower stops.

BODY MAINTENANCE AND CARE

	Page
Body maintenance	90
- Protecting the car	90
- Paint	91
- Body	91
- Undercarriage	91
- Interior	92
- Windows	92
- Engine compartment	93
- Cleaning plastic parts	93
Vehicle Storage	93

Protecting the car

LANCIA has implemented numerous production steps to greatly improve the car's resistance to corrosion caused by chemical agents including:

- Air pollution.
- Airborne salt and humidity (seaside areas or hot, humid climates).
- Road salt (used in winter to prevent ice formation).

Dust and fumes, as well as sand, mud and gravel kicked up while driving have an abrasive action on the paint and undercarriage.

The following high-tech solutions have been adopted to deal with this complex problem:

- Use of corrosion- and abrasion-resistant paints and paint application systems.
- Use of galvanized body panels which are highly resistant to corrosion.
- Extensive use of undercoating compounds and a protective engine compartment coating which have an exceptionally high affinity for metal.
- Use of pollution-resistant enamels.

- Spraying of protective resins on exposed areas such as door jambs, rocker panels and bumpers.
- Open-box cross and side member chassis construction to prevent the buildup of water that can lead to rust formation.

The factors described are diverse and vary depending on the environmental conditions where you drive. However, if you take a few minutes to take care of your car from time to time, it will last a lot longer.

The suggestions on the following pages will help you to maintain your car's body, paint and upholstery.

Paint - Body

The paint not only makes your car beautiful, it also protects the sheet steel under it.

Chipping or deep scratches should be immediately touched up to prevent rust.

Always use original paint for touching up (refer to paint ID plate on p.97).

Wash your car regularly to keep the paint in good condition. Wash more frequently in areas with high air pollution levels or when parking under trees (sap may drip onto the car).

Remove bird droppings immediately as uric acid will damage the paintwork. Thoroughly wash the car as soon as possible.

Wet the car using a low-pressure jet of water. Use a soft sponge dipped in a 2-4% solution of car wash or other detergent. Rinse the sponge often while washing the car. Then, rinse thoroughly and dry the car with a chamois-leather cloth.

Dry the entire car including less visible areas such as the door frames, bonnet and headlamp housings-areas where water can stagnate.

Do not park the car in a closed garage soon after washing it to allow for adequate air circulation facilitating the evaporation of the remaining water.

Do not wash the car if it has been parked in the sun or if the bonnet is still hot to avoid damaging the high-gloss finish.

Use good quality car care products such as silicone wax that create a protective layer on the paint and help to maintain the car's original lustre. If you notice dull areas, use a slightly abrasive wax polish to restore the paint.

Undercarriage

LANCIA has treated all areas of the undercarriage with a protective coating using state-of-the-art techniques.

However, the undercarriage should be checked occasionally, especially if the car is regularly driven under adverse conditions.

BODY MAINTENANCE

Undercarriage inspections should also be performed to check the mechanical assemblies. Deal immediately with any problems observed.

Some chassis members are sealed with plugs. Remove them during the inspection to check for rust.

If the car is often driven in areas with severe climates, treat the chassis and door jambs with protective compounds more often.

Appropriate products should be applied by a body shop to the undercarriage.

Have this done at least **every two years** (annually under severe conditions) at the beginning of winter.

Interior

It is also important to take care of the car's interior.

Check that there is no water under the floor mats (from dripping umbrellas) that could lead to rust formation.

Remove dust from the **seat upholstery** with a soft brush.

Remove grease stains with an appropriate product. Always follow the manufacturer's instructions carefully.

Use a sponge dampened in soapy water ($\frac{1}{2}$ oz. per gallon of water) if the seats are very dirty.

Windows

Clean the windows using an appropriate glass cleaner. Always use a clean cloth to prevent streaking and scratches.

Clean the inside of the rear window carefully to avoid damaging the embedded defroster wires. Rub only horizontally.

Engine compartment

The engine compartment should be thoroughly washed at the end of winter to remove road salt.

Cleaning plastic parts

Clean the exterior plastic parts when washing the car.

If still dirty, use an appropriate plastic cleaner. Follow the manufacturer's instructions carefully. Never use paint cleaning compounds on plastic.

Do not use alcohol to clean the instrument panel.

Avoid cleaning interior plastic parts with products that polish the plastic (e.g., compounds containing silicone) as they will alter the appearance of parts with a matte finish. Use soapy water (add a surfactant if possible), a dilute alcohol solution (but never on the instrument panel) or a detergent sold expressly for cleaning plastic.

Suggestions

If you are not planning on using your car for several months, do the following:

- Clean and protect the paint with silicone wax. Clean the chrome parts using an appropriate compound.
- Park the car in a dry, covered place with adequate ventilation.
- Release the handbrake.
- Disconnect the battery cables.
- Remove the wiper blades and coat them with talc.
- Open the windows about an inch.
- Cover the car with a tarpaulin that breathes. Never use a sheet of plastic as it will trap moisture.
- Increase the tyre pressures at least 0.5 bar more than indicated in the table on p. 110. Verify pressure from time to time.
- Every 1½ months perform a battery state-of-charge check. Recharge using a trickle charger for 24 hours.
- Do not drain the coolant.

SPECIFICATIONS

	Page
Vehicle identification	96
Engine	98
Brakes	100
Steering	100
Suspension	101
Transmission	101
Wheels	102
Wheel alignment	103
Electrical system	103
Performance	104
Weights	104
Dimensions	105
Capacities	106
Lubricant and fluid specifications	108
Fuel consumption	110
Tyre pressures	110

VEHICLE IDENTIFICATION

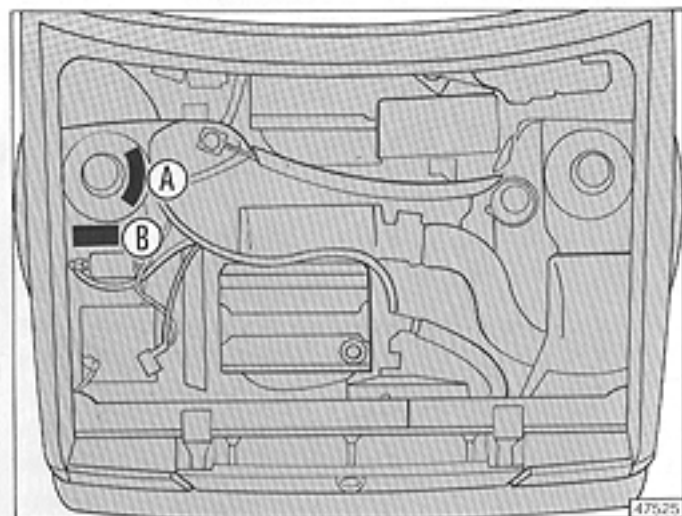

A - Chassis code numbers

- Vehicle code: ZLA 831 AB0
- Serial number.

B - Model plate

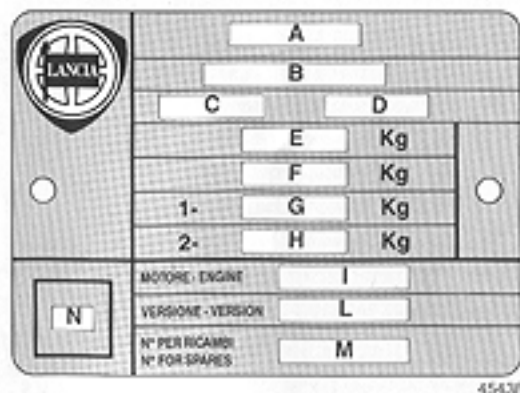

- A. Manufacturer.
- B. Homologation number.
- C. Vehicle ID code.
- D. Chassis serial number.
- E. Maximum gross vehicle weight.
- F. Maximum gross vehicle weight including trailer.
- G. Maximum gross vehicle weight at front axle.
- H. Maximum gross vehicle weight at rear axle.
- I. Engine code.
- L. Body code.
- M. Number for spares.
- N. Diesel engine smoke opacity index.

VEHICLE IDENTIFICATION

Body code

Delta 1.5 LX	831 AB.025
Delta GT i.e.	831 AB.016
Delta HF turbo	831 AB.020

Engine code

- Engine type

Delta 1.5 LX	831 B1.000
Delta GT i.e.	831 B7.000
Delta HF turbo	831 B3.000

- Engine serial number

The above information is stamped in the following locations:

Delta with 1500 cc engine	On trasmission side of engine block.
Delta with 1600 cc engine	On engine block behind oil filter.

Paint identification plate

This plate is located inside the hatchback door.

- A. Paint manufacturer.
- B. Colour name.
- C. Colour code.
- D. Respray and touch-up code.

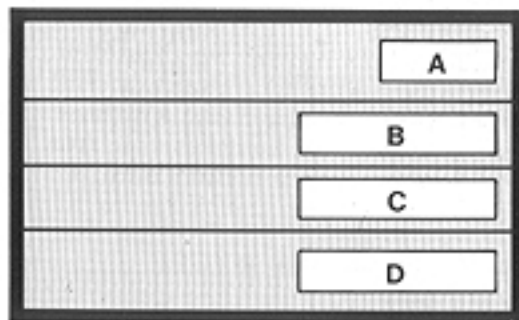

45437

ENGINE

Engine specifications	Delta 1.5 LX	Delta GT i.e.	Delta HF turbo
Engine code	831 B1.000	831 B7.000	831 B3.000
Cycles	4-cycle	4-cycle	4-cycle
Number of cylinders	inline-4	inline-4	inline-4
Bore x stroke mm	86.4 × 63.9	84 × 71.5	84 × 71.5
Displacement cm ³	1498	1585	1585
Compression ratio	9.2:1	9.2:1	7.5:1
Torque (EEC) Nm (kgm) at rpm	122 (12.4) 3200	132 (13.5) 3500	191 (19.5) 3500
Horsepower (EEC) kW (bhp) at rpm	59 (80) 5600	80 (108) 5900	103 (140) 5500
Timing			
Number of overhead cams	1	2	2
Timing belt drive	toothed belt	toothed belt	toothed belt
Inlet { opens BTDC	7°	11°	0°
{ closes ABDC	35°	48°	40°
Exhaust { opens BBDC	37°	51°	40°
{ closes ATDC	5°	8°	0°
Timing check clearances (inlet and exhaust) mm	0.80	0.80	0.70
Valve clearances when cold			
- inlet mm	0.40 ± 0.05	0.40 ± 0.04	0.40 ± 0.04
- exhaust mm	0.50 ± 0.05	0.50 ± 0.04	0.50 ± 0.04

ENGINE

	Delta 1.5 LX	Delta GT i.e.	Delta HF turbo
Ignition			
Electronic ignition	Digiplex (inductive discharge)	Integrated static advance	Integrated static advance with fuel injection firing sensor
Firing order	1-3-4-2	1-3-4-2	1-3-4-2
Spark plugs:			
Fiat	W45LSR	W45LSR	-
Magneti Marelli	F8LCR	F8LCR	-
Bosch	WR6DC	WR6DC	WR6DTC
Champion	RN7YC	RN7YC	-
Spark plug gap	0.7-0.8 mm	0.7-0.8 mm	0.8-1 mm
Fuel delivery			
Type	Aspirated	Aspirated	Turbocharged*
Fuel pump	Mechanical	Electrical	Electrical
Weber carburettor	32/34TLDA9	-	-
Weber fuel injection	-	IAW electronic integrated with ignition	IAW electronic integrated with ignition
Air cleaner	Dry	Dry	Dry

* Garret T2 water-cooled turbocharger with air-to-air heat exchanger and overboost.

Lubrication

Forced-feed gear pump.

Full-flow cartridge oil filter.

The turbocharger of supercharged engines is lubricated by engine oil cooled by a heat exchanger.

Cooling system

The cooling system components include a radiator, centrifugal pump and expansion tank. A thermostatic valve is located on the cylinder head outlet. A secondary recirculation circuit feeds the the heating system radiator.

Thermostatically controlled radiator fan.

Overboost (Delta HF turbo)

The overboost excludes the wastegate valve, which controls the exhaust gases that drive the turbocharger to maintain a uniform engine feed pressure. When the overboost function is operative a panel indicator illuminates (see pp.14-15).

The overboost is actuated at engine speeds above 4750 rpm when pressing the accelerator pedal fully down. Releasing the accelerator pedal de-activates the overboost.

Service brakes

Front disc and rear drum brakes (1.5 LX).

Four-wheel disc brakes (GT i.e. and HF turbo).

Dual diagonally split brake circuits.

Vacuum servo.

Rear brake pressure proportioning valve.

Some versions have front brake air cooling ports instead of supplementary headlamps.

Handbrake

Mechanical, lever-actuated handbrake linked to rear brakes.

Steering

Rack-and-pinion permanently lubricated system with ball joints (with shock absorption for GT i.e. and HF turbo).

TRW rack-and-pinion power steering (if fitted) with pump and fluid reservoir.

Shock-absorbing, height-adjustable steering column.

Turning circle 10.5 metres

Turns, lock to lock 3.94
(power steering: 3.35)

SUSPENSION - TRANSMISSION

Suspension

Front: Independent, MacPherson suspension with track control arm, hydraulic dampers and antiroll bar.

Rear: Independent, MacPherson suspension with two transverse track control arms, lower longitudinal strut, Hydraulic damper and dual-acting coil springs, antiroll bar.

Transmission

Clutch

Self-adjusting, mechanical linkage, no pedal free travel.

Transaxle

Five-speed synchromesh and reverse manual transmission.

Gear ratios:

	Delta 1.5 LX	Delta GT i.e.	Delta GT i.e.*	Delta HF turbo
1 st gear	3.909	3.545	3.909	3.545
2 nd gear	2.267	2.267	2.267	2.267
3 rd gear	1.469	1.523	1.440	1.541
4 th gear	1.043	1.142	1.029	1.156
5 th gear	0.863	0.967	0.906	0.891
Reverse	3.909	3.909	3.667	3.909

Differential gears incorporated in transmission case.

Final drive ratios:

Delta 1.5 LX	16/57
Delta GT i.e.	16/57
Delta GT i.e.*	15/57
Delta HF turbo	17/57

Power transmitted to the front wheels by axle halfshafts. Transaxle and wheels linked by constant-velocity joints.

* France only.

WHEELS

Rims and tyres

Rims aluminium alloy

Tyres tubeless radials

Dimensions:

	Rims	Tyres
1.5 LX* - GT i.e.	5½J - 14" AH2	165/65 R 14" 78T
HF turbo	5½J - 14" H2	185/55 R 14" 79V

* Rims for this model must be mounted using a 3-mm spacer plate.

Spare

Stamped steel rim 4.00 B - 14" H

Tubeless tyre 135/80 B 14

Important: Never use inner tubes in tubeless tyres.

Snow chains

Maximum height 12 mm

Installation and use see p. 87

Wheel alignment

The values given are for unladen cars.

Front wheel toe-in: 2.5 - 1 mm.

Rear wheel toe-in: 2 - 5 mm.

Electrical system voltage: 12 volts.

Battery (negative ground)

	Capacity (20-h discharge rate)	Cold cranking power (-18°C)
Delta 1.5 LX Delta GT i.e. Delta HF turbo	40 Ah	200 A

Alternator

Nine-diode rectifier with integral voltage regulator.

Battery recharged as soon as engine starts.

	Nominal output
Delta 1.5 LX	55 A
Delta GT i.e. Delta HF turbo	65 A

PERFORMANCE - WEIGHTS

Performance

Maximum speeds after running in (km/h):	Delta 1.5 LX	Delta GT i.e.	Delta GT i.e.*	Delta HF turbo
1 st gear	45	55	50	55
2 nd gear	85	85	90	90
3 rd gear	130	125	140	130
4 th gear	165	165	182	175
5 th gear	160	185	179	203
Reverse	50	50	50	50
Maximum gradeability in a fully laden car (%):				
1 st gear	37	38	38	39
2 nd gear	23	25	23	34
3 rd gear	14	16	13	21
4 th gear	8	10	8	15
5 th gear	6	7	6	10
Reverse	41	47	44	59

* France only.

Weights (kg)

	Delta 1.5 LX	Delta GT i.e.	Delta HF turbo
Kerb weight (includes fuel, spare and tools)	955	995	1020
Payload (5 occupants + 100 kg luggage)	450	450	450
Maximum gross vehicle weight	1405	1445	1470

DIMENSIONS

Dimensions (milimetres)

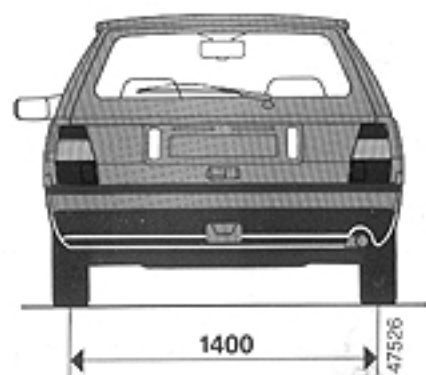
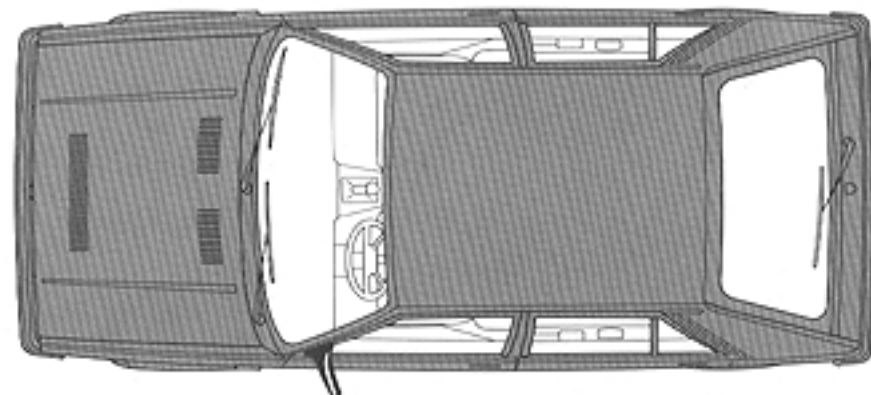
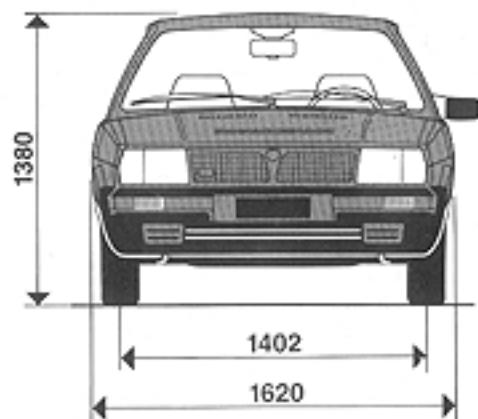
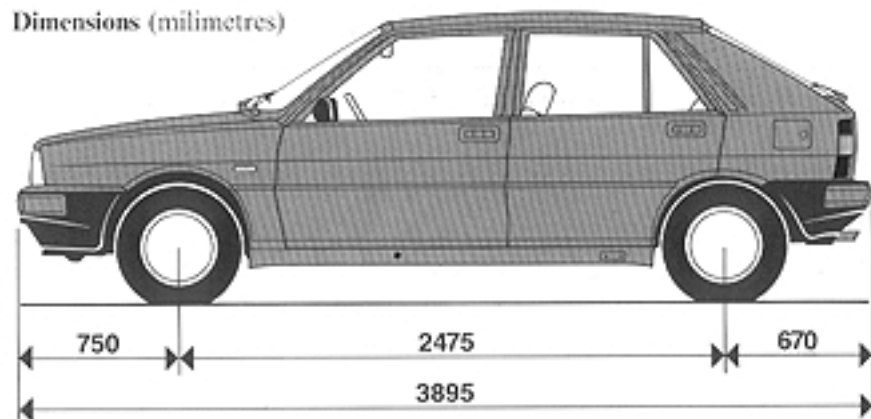

The height indicated is for an unladen car.

Luggage compartment capacity (VDA standards): 260 dm³.

Luggage compartment capacity with rear seat folded down (VDA standards): 1000 dm³.

Capacities	Delta 1.5 LX		Delta GT i.e.		Delta HF turbo		Fuels and recommended products*
	dm ³ (litres)	kg	dm ³ (litres)	kg	dm ³ (litres)	kg	
Fuel tank including a reserve of	57 6 - 9	-	57 6 - 9	-	57 6 - 9	-	} Premium petrol** 50-50 mixture of distilled water and FIAT Paraffin' ***
Cooling system	6	-	6.50	-	6.50	-	
Engine sump	4.10	3.65	4.50	4.00	4.30	3.85	} Refer to p. 107
Engine sump and filter	4.30	3.90	5.00	4.40	4.80	4.25	
Sump, filter and lines	4.40	4.00	5.30	4.80	5.90	5.30	
Transaxle	2.00	1.80	-	-	-	-	Tutela ZC 90 oil
Transaxle	-	-	2.00	1.80	2.00	1.80	Tutela ZC 80S oil
Steering gear	0.095	0.080	0.095	0.080	0.095	0.080	Tutela K 854 grease
Hydraulic power steering	-	-	-	0.61	-	0.61	Tutela GI/A fluid
CV-joint cavities and boots (each) ...	-	0.10	-	0.10	-	0.10	Tutela MRM 2 grease
Front/rear hydraulic brake circuits ...	-	0.30	-	0.30	-	0.30	Tutela DOT 4 fluid
Windscreen/rear window washer reservoir	2	-	2	-	2	-	Mixture of water and Autofa n. 9 DP1***

* Product specifications are given on p. 108.

** Either leaded or unleaded premium petrol (minimum octane number 95) can be used.

*** Refer to *A note about the fluids* on p. 107.

Oil change and filter replacement after free service coupon

Version	Recommended engine oil	Change interval	
		Engine oil	Oil filter
Delta 1.5 LX	SELENIA	Every 20,000 km or 12 months	Every 20,000 km
Delta GT i.e.	SELENIA	Every 15,000 km or 12 months	Every 15,000 km
Delta HF turbo	SELENIA	Every 10,000 km or 12 months	Every 10,000 km

Do not top up with oils that have different specifications.

Average oil consumption values

Delta 1.5 LX	50 - 60 g/100 km
Delta GT i.e.	80 - 90 g/100 km
Delta HF turbo	110 - 120 g/100 km

A note about the fluids

- A 50-50 mixture of **FIAT Parafiu[®]** and distilled water gives freeze protection down to -35°C .
- Mix 30 cl of **Autofà n.9 DPI** with a litre of water for summer use. In climates where winter temperatures may go as low as -20°C , mix equal amounts of water and **Autofà n.9 DPI**. Use **Autofà n.9 DPI** undiluted in areas with severe winters (below -20°C).

Product characteristics

Use	Specifications	Recommended fluids and lubricants	Specific application
Petrol engine lubricants	SAE 15W/40 semisynthetic multigrade oil; exceeds API-SG, CCMC-G4 and CUNA NC 610-01 CL-G2 specifications.	SELENIA	Operating range* -15°C-40°C.
Lubricants and greases for transmissions	SAE 80W/90, non-EP antiwear oil.	TUTELA ZC 90	Transmissions and differentials w/o hypoid gears
	SAE 80W EP oil. Meets API GL4 and MIL-L-2105 specifications.	TUTELA ZC 80/S	Manual transmissions and differentials
	SAE 80W/90 EP oil for standard and limited-slip differentials. Meets API GL5 and MIL-L-2105 C specifications.	TUTELA W 90/MDA	Hypoid differentials. Limited-slip differentials. Steering rack.
	Molybdenum disulphide, lithium-soap base grease; NLGI consistency no. 2.	TUTELA MRM 2	CV joints.
	Lithium soap grease; NLGI consistency no. 3.	TUTELA MR 3	Wheel bearings. Steering linkage.

* At temperatures below -15°C use SAE 10W/30 (Selenia 10W/30 is recommended).

Use	Specifications	Recommended fluids and lubricants	Specific application
Steering rack lubricant	Lithium soap grease; NLGI consistency no. 000; contains molybdenum sulphide.	TUTELA K 854	
Hydraulic brake fluid	Synthetic fluid; F.M.V.S.S. no. 116, DOT 4, ISO 4925, CUNA NC 956-01.	TUTELA DOT 4	
	Grease compatible with brake fluid.	SP 349	Brake load proportioning valve, Linkage bushings.
Radiator antifreeze	Ethylene glycol antifreeze; CUNA NC 956-16.	FIAT PARAFLU [®]	50-50 mixture with water protects to -35°C
Windscreen/head-lamp washer fluid	Mixture of water, alcohols and surfactants; CUNA NC 956-11.	AUTOFA n. 9 DP1	Use diluted or undiluted
Chassis grease	Lithium soap grease; NLGI consistency no. 1.	TUTELA JOTA 1	All components not exposed to water. Use special greases for areas in contact with water.

Fuel consumption as per EEC standards - litres/100 km (miles/Imp. gal.)

Version	City driving	Constant speed 90 km/h (56 mph)	Constant speed 120 km/h (75 mph)
Delta 1.5 LX	9.1 (31.0)	5.5 (51.4)	7.2 (39.2)
Delta GT i.e.	9.9 (28.5)	7.0 (40.3)	9.2 (30.7)
Delta GT i.e. *	9.7 (29.1)	5.8 (48.7)	7.7 (36.7)
Delta HF turbo	10.0 (28.3)	6.5 (43.5)	8.4 (33.6)

* France only.

The fuel consumption values listed in the table above were determined in official tests utilizing procedures defined in EEC directives. Simulated city driving fuel consumption is measured on a test-bed, while constant speed (90 and 120 km/h - 56 and 75 mph) fuel economy is measured both on a dry, level test track and using test-bed procedures.

These values may be useful for comparing different vehicles.

Actual fuel consumption may be slightly different from official values owing to diverse traffic conditions, driving style, the weather and the car's general condition.

Cold tyre pressures (expressed in bar)

	Delta 1.5 LX - GT i.e.	Delta HF turbo
Average load	2	2.2
Fully laden	2.2	2.4
Spare	2.8	2.8

APPENDIX

	Page
Sound system installation	112
Tow-hitch installation	114
Alarm system installation	116

All electrical accessories not discussed in this handbook should be installed via a relay governed by the ignition switch.

SOUND SYSTEM INSTALLATION

Where to install the sound system components

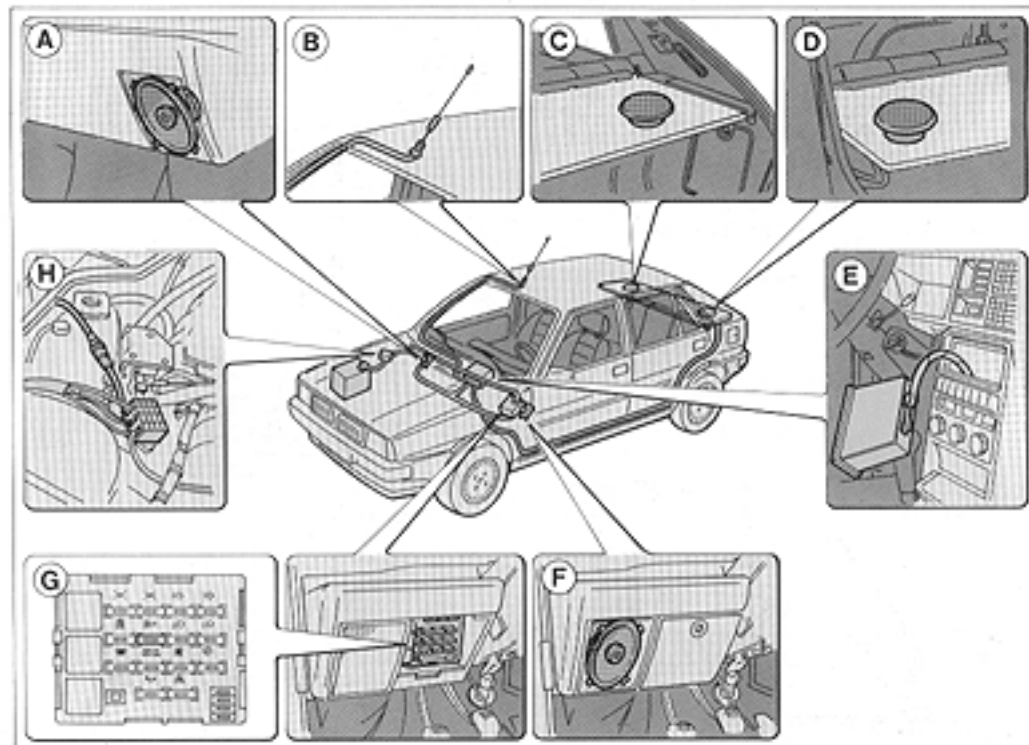

47833

- A. Right front speaker.
- B. Antenna.
- C. Right back speaker.
- D. Left back speaker.
- E. Radio housing.
- F. Left front speaker.
- G. Fuse box.
- H. Supplementary amplifier power supply fuse (if system power exceeds 4x20 W).

TOW HITCH INSTALLATION

Wiring schematic

- A. Stop light switch connection.
- B. 7-pin socket.
- C. Ground from 7-pin socket.
- D. Power supply takeoff for direction indicators.
- E. Power supply takeoff for taillights.
- F. Power supply connection for electromagnetic braking system.

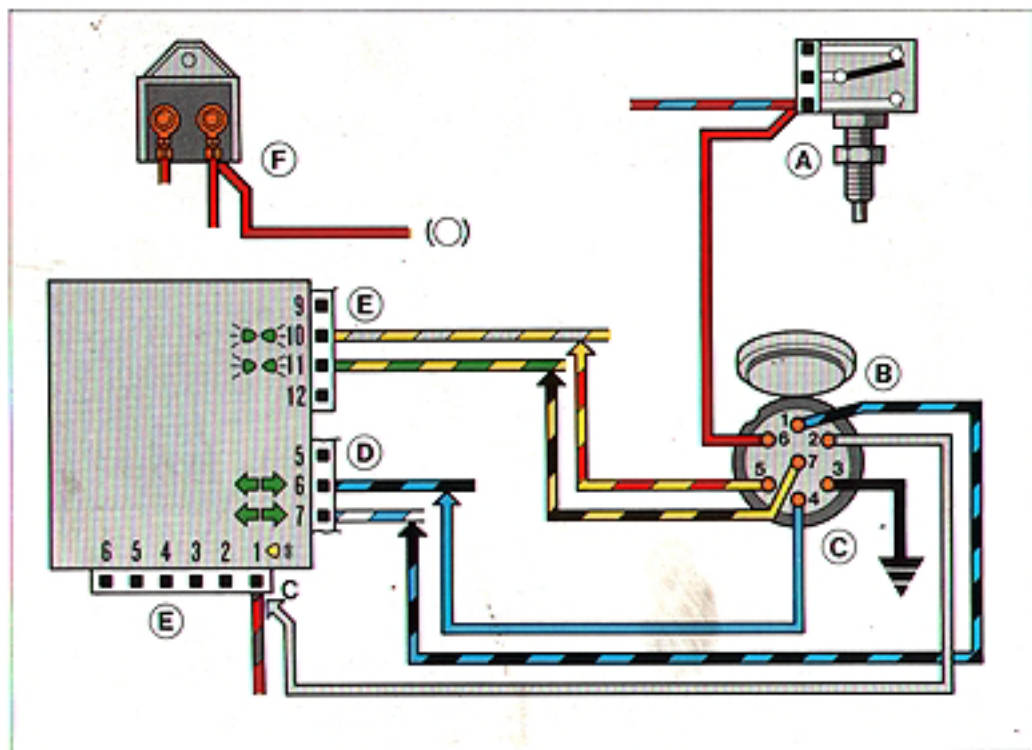

47834

TOW HITCH INSTALLATION

Where to connect the tow hitch wiring

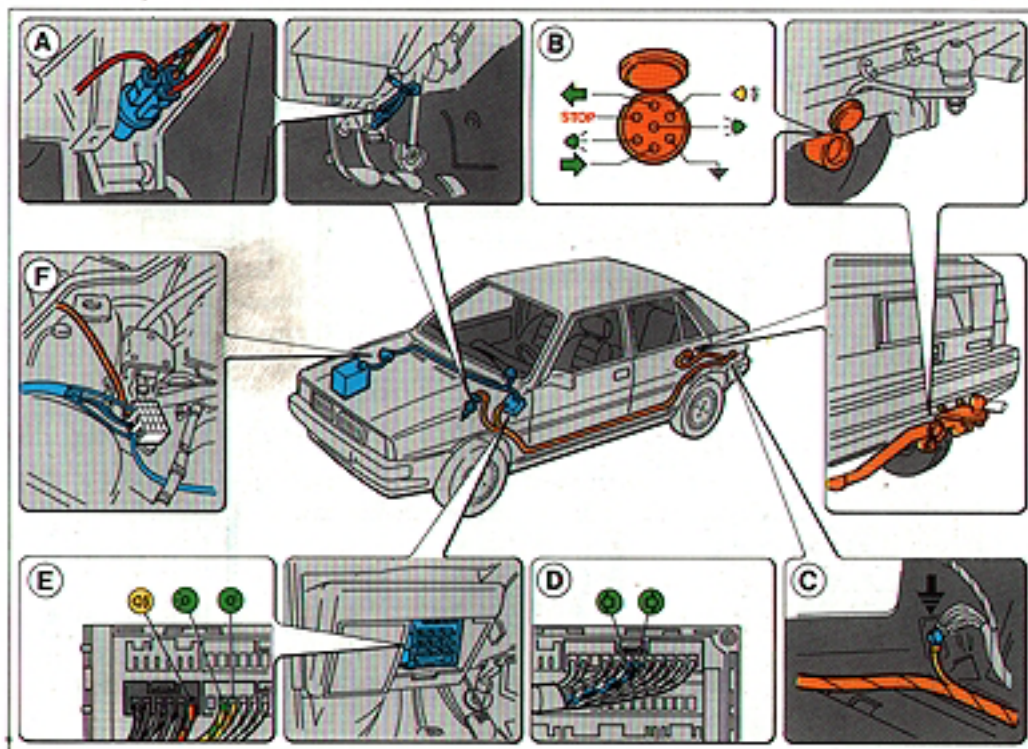

47835

NB - The person installing the tow hitch is required to attach a clearly legible plate made of an appropriate material at the same height as the coupling with the following stamped on it:

MAXIMUM LOAD AT THE COUPLING: 70 kg.

ALARM SYSTEM INSTALLATION

Wiring schematic

- A. Ultrasonic detector.
- B. Connection to power window system for alarm system window control.
- C. Connection to power lock system to allow remote control by the alarm system.
- D. Hatchback door opening detector.
- E. Connection for control of direction indicator flasher by alarm system.
- F. Siren.
- G. Alarm system control unit.
- H. Bonnet opening sensor.

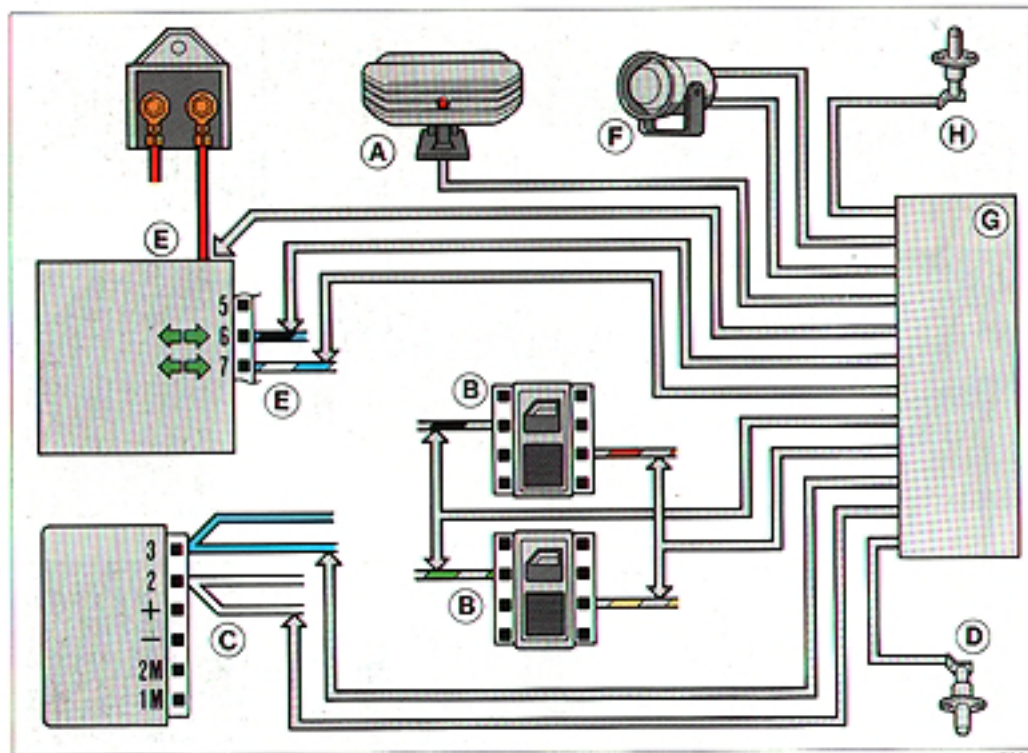

47836

NB - When switches B are open, the cables connected to the power window motors are grounded. This fact should be taken into account when wiring the system.

ALARM SYSTEM INSTALLATION

Where to connect the alarm system wiring

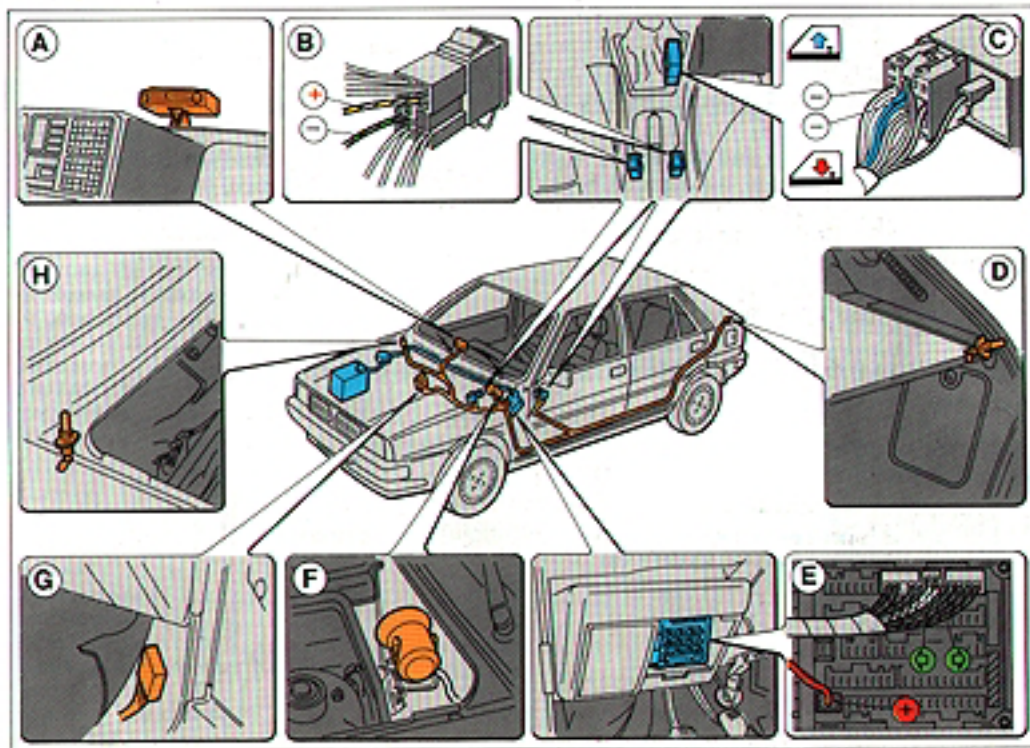

47837

- A. Ultrasonic detector.
- B. Connection to the power window system enabling the alarm system to close the windows when armed.
- C. Connection to the power lock system for remote control of the alarm system.
- D. Hatchback door opening detector.
- E. Connection for control of direction indicator flasher when alarm system is armed.
- F. Siren.
- G. Alarm system control unit.
- H. Bonnet opening control unit.

The following suggestions will help you to keep your car's polluting exhaust emissions low.

- Perform maintenance at regular intervals and do repairs when necessary. Particular attention should be given to the engine (spark plugs, air cleaner, breaker points, ignition advance, injectors, injection pump timing, exhaust system and valve clearances).
- Let the engine run at idle only briefly.
- Use the choke for as short a time as possible.
- If you have diesel engine, drive your car immediately after starting it. Do not let it warm up at idle.
- Never floor the accelerator when moving off or double-clutch when shifting gears. Both will increase fuel consumption and exhaust emissions.
- Every vehicle condition that increases fuel consumption (overloading, underinflated tyres, poor wheel alignment) will increase exhaust emissions.

INDEX

	Page		Page
Appendix.....	111	Check system	21
Body care and maintenance	89	Checking fluid levels	77
Driving your car.....	51	Cigarette lighter	46
Getting acquainted with your car.....	5	Cleaning plastic parts.....	93
Maintenance and servicing	71	Cleaning the body	91
Specifications	95	Cleaning the engine compartment	93
What to do if.....	59	Cleaning the interior	92
		Cleaning the windows	92
A		Clock	23
Adjusting engine idle	84	Clutch	
Adjusting the low beam headlamps	44	adjusting pedal height	85
Air cleaner, replacing the filter element.....	81	specifications	101
Air conditioner	27	Coolant	79
Air vents	25,27-28	Coolant temperature gauge	20
Alternator	84,103	Cooling system.....	100
Alternator belt		Courtesy lights	47
adjusting	84	replacing the bulbs	63
Ashtray	46		
		D	
B		Dashboard	6
Back-up and number plate lights		Defogging or defrosting	
replacing the bulbs	65	rear window	30
Battery		windscreen	26,29
maintenance	82	Dimensions	105
recharging	68	replacing the bulbs	64
specifications	103	stalk	32
starting with another battery	68	Doors	38
Bonnet		childproof locks	38
opening and closing	43	power locks	39
Brake fluid	79	power windows	40
		Driving comfort and safety.....	53
C			
Capacities	106		
Carburettor, adjusting the idle	84		

	Page
E	
Electrical system	103
Electronic control units	83
Emergency starting	52
Engine lubrication, specifications	100
Engine oil	
changing	77,107
checking the level	77
Engines pecifications	98
Exterior lighting stalk	31
F	
Free service coupon	72
Front fog lamps	
switch	30
Front seat adjustment	
Fuel	46,106
Fuel consumption	110
Fuel economy	54
Fuel economy gauge	18
Fuel filler door	46
Fuel filter	81
Fuel gauge	20
Fuel supply and ignition	99
Fuel tank reserve	20,106
Fuses	66
G	
Gear ratios	101
Gearshift lever	53
Glove compartment	47
Gradeability	104

	Page
H	
Handbrake	100
adjusting	85
indicator light	17
Hazard warning lights	
switch	30
Headlamps	
adjusting from inside car	45
beam alignment	44
replacing the bulbs	63
stalk	31
Headrests	34
Heating system filter	88
High beam headlamps	31
replacing the bulbs	63
I	
Ignition switch	9
Indicator and warning lights	16
Instrument panel	10,15
Instrument panel dimmer	30
J	
Jack	60,69

	Page
K	
Keys	9
L	
Low beam headlamp correctors	45
Low beam headlamps	31
replacing the bulbs	63
Lubricants	
engine oil	107
specifications	108,109
Lubrication servicing	75
Luggage compartment light	48
replacing the bulb	63
Luggage compartment	
increasing the cargo area	41
opening and closing	39
volume	105
M	
Maintenance and servicing	71
Maximum speeds.....	104
Model plate	96
O	
Odometer and trip odometer	16
Oil consumption	107
Oil filter	81
Oil pressure gauge	24
Oil temperature gauge	18,20-24
Overboost	100

	Page
P	
Passenger compartment heating	25,29
air conditioner	27
Performance	
gradeability	104
speeds	104
Power locks	39
Power steering fluid	78
Power windows	40
Protecting the environment	118
R	
Radiator fan warning	43
Raising the car	
with a hydraulic shop jack	69
with a jack	60
Rear fog-guard lights, switch	30
Rear seats, folding down to increase cargo area	41
Rear window defroster, switch	30
Rear window washer	30,88
Rear window wiper	
cleaning/replacing the blades	88
switch	30
Rearview mirrors	33
Replacing a wheel	60
Rev counter	19
Rims	102

	Page
S	
Safety and comfort	35
Seat belts	35
Service brakes	
specifications	100
Side lights	31
replacing the bulbs	64,65
Snow chains	87,102
Sound system	50,112-113
Spare	62,102
Spark plugs	
maintenance	83
types and specifications	99
Speedometer	16
Starting the engine	52
Steering column lock	9
Steering wheel adjustment	33
Steering specifications	100
Stop lights	
replacing the bulbs	65
Sun visors	48
Sunroof	49
Suspension specifications	101
Switch panel	30
T	
Timing	98
Tow hitch	55,114
Tow hitch	55
electrical schematic	56,114
installation	57,115

	Page
Transmission	
gear ratios	101
Transmission oil	
checking the level, changing	77
shifting gears	53
Turbocharger pressure gauge	18
Tyres	
changing a flat	60
inflation pressures	110
maintenance	86
snow chains	87,102
types	102
V	
Valve clearances	98
Vehicle alarm system	116,117
Vehicle identification	96
Vehicle storage	93
Ventilation	25
Voltmeter	19
W	
Weights	104
Wheel alignment (toe-in)	103
Windscreen washer	32,88
Windscreen wiper	
cleaning/replacing the blades	88
stalk	32
Windscreen/rear window washer fluid	80,107